

INSTRUCTION MANUAL

Serial Number _____

5A20N **DIFFERENTIAL** **AMPLIFIER**

CALIBRATION TEST EQUIPMENT REPLACEMENT

Calibration Test Equipment Chart

This chart compares TM 500 product performance to that of older Tektronix equipment. Only those characteristics where significant specification differences occur, are listed. In some cases the new instrument may not be a total functional replacement. Additional support instrumentation may be needed or a change in calibration procedure may be necessary.

Comparison of Main Characteristics

DM 501 replaces 7D13		
PG 501 replaces 107	PG 501 - Risetime less than 3.5 ns into 50 Ω .	107 - Risetime less than 3.0 ns into 50 Ω .
108	PG 501 - 5 V output pulse; 3.5 ns Risetime.	108 - 10 V output pulse; 1 ns Risetime.
111	PG 501 - Risetime less than 3.5 ns; 8 ns Pretrigger pulse delay.	111 - Risetime 0.5 ns; 30 to 250 ns Pretrigger Pulse delay.
114	PG 501 - ± 5 V output.	114 - ± 10 V output. Short proof output.
115	PG 501 - Does not have Paired, Burst, Gated, or Delayed pulse mode; ± 5 V dc Offset. Has ± 5 V output.	115 - Paired, Burst, Gated, and Delayed pulse mode; ± 10 V output. Short-proof output.
PG 502 replaces 107		
108	PG 502 - 5 V output	108 - 10 V output.
111	PG 502 - Risetime less than 1 ns; 10 ns Pretrigger pulse delay.	111 - Risetime 0.5 ns; 30 to 250 ns Pretrigger pulse delay.
114	PG 502 - ± 5 V output	114 - ± 10 V output. Short proof output.
115	PG 502 - Does not have Paired, Burst, Gated, Delayed & Undelayed pulse mode; Has ± 5 V output.	115 - Paired, Burst, Gated, Delayed & Undelayed pulse mode; ± 10 V output. Short-proof output.
2101	PG 502 - Does not have Paired or Delayed pulse. Has ± 5 V output.	2101 - Paired and Delayed pulse; 10 V output.
PG 506 replaces 106	PG 506 - Positive-going trigger output signal at least 1 V; High Amplitude output, 60 V.	106 - Positive and Negative-going trigger output signal, 50 ns and 1 V; High Amplitude output, 100 V.
067-0502-01	PG 506 - Does not have chopped feature.	0502-01 - Comparator output can be alternately chopped to a reference voltage.
SG 503 replaces 190, 190A, 190B	SG 503 - Amplitude range 5 mV to 5.5 V p-p.	190B - Amplitude range 40 mV to 10 V p-p.
191	SG 503 - Frequency range 250 kHz to 250 MHz.	191 - Frequency range 350 kHz to 100 MHz.
067-0532-01	SG 503 - Frequency range 250 kHz to 250 MHz.	0532-01 - Frequency range 65 MHz to 500 MHz.
TG 501 replaces 180, 180A	TG 501 - Marker outputs, 5 sec to 1 ns. Sinewave available at 5, 2, and 1 ns. Trigger output - slaved to marker output from 5 sec through 100 ns. One time-mark can be generated at a time.	180A - Marker outputs, 5 sec to 1 μ s. Sinewave available at 20, 10, and 2 ns. Trigger pulses 1, 10, 100 Hz; 1, 10, and 100 kHz. Multiple time-marks can be generated simultaneously.
181	TG 501 - Marker outputs, 5 sec to 1 ns. Sinewave available at 5, 2, and 1 ns.	181 - Marker outputs, 1, 10, 100, 1000, and 10,000 μ s, plus 10 ns sinewave.
184	TG 501 - Marker outputs, 5 sec to 1 ns. Sinewave available at 5, 2, and 1 ns. Trigger output - slaved to marker output from 5 sec through 100 ns. One time-mark can be generated at a time.	184 - Marker outputs, 5 sec to 2 ns. Sinewave available at 50, 20, 10, 5, and 2 ns. Separate trigger pulses of 1 and .1 sec; 10, 1, and .1 ms; 10 and 1 μ s. Marker amplifier provides positive or negative time marks of 25 V min. Marker intervals of 1 and .1 sec; 10, 1, and .1 ms; 10 and 1 μ s.
2901	TG 501 - Marker outputs, 5 sec to 1 ns. Sinewave available at 5, 2, and 1 ns. Trigger output - slaved to marker output from 5 sec through 100 ns. One time-mark can be generated at a time.	2901 - Marker outputs, 5 sec to 0.1 μ s. Sinewave available to 50, 10, and 5 ns. Separate trigger pulses, from 5 sec to 0.1 μ s. Multiple time-marks can be generated simultaneously.

NOTE: All TM 500 generator outputs are short-proof. All TM 500 plug-in instruments require TM 500-Series Power Module.



WARRANTY

All Tektronix instruments are warranted against defective materials and workmanship for one year.

Any questions with respect to the warranty, mentioned above, should be taken up with your Tektronix Field Engineer or representative.

All requests for repairs and replacement parts should be directed to the Tektronix Field Office or representative in your area. This procedure will assure you the fastest possible service. Please include the instrument Type (or Part Number) and Serial or Model Number with all requests for parts or service.

Specifications and price change privileges reserved.

Copyright © 1971 by Tektronix, Inc., Beaverton, Oregon. Printed in the United States of America. All rights reserved. Contents of this publication may not be reproduced in any form without permission of the copyright owner.

U.S.A. and foreign Tektronix products covered by U.S. and foreign patents and/or patents pending.

MANUAL CHANGE INFORMATION

At Tektronix, we continually strive to keep up with latest electronic developments by adding circuit and component improvements to our instruments as soon as they are developed and tested.

Sometimes, due to printing and shipping requirements, we can't get these changes immediately into printed manuals. Hence, your manual may contain new change information on following pages.

A single change may affect several sections. Since the change information sheets are carried in the manual until all changes are permanently entered, some duplication may occur. If no such change pages appear following this page, your manual is correct as printed.

SERVICE NOTE

Because of the universal parts procurement problem, some electrical parts in your instrument may be different from those described in the Replaceable Electrical Parts List. The parts used will in no way alter or compromise the performance or reliability of this instrument. They are installed when necessary to ensure prompt delivery to the customer. Order replacement parts from the Replaceable Electrical Parts List.

TABLE OF CONTENTS

SECTION 1	SPECIFICATION	Page
	Introduction	1-1
	Table 1-1 Electrical Characteristics	1-1
	Table 1-2 Environmental Characteristics	1-2
SECTION 2	OPERATING INSTRUCTIONS	
	Plug-in Insertion and Removal	2-1
	Controls and Connectors	2-1
	First Time Operation	2-2
	Preparation	2-2
	Step Attenuator Balance Adjustment	2-2
	Gain Check	2-2
	General Operating Information	2-3
	Applying Signals	2-3
	Signal Input Connectors	2-3
	High Impedance Input	2-4
	Display Polarity	2-4
	Deflection Factor	2-4
	Voltage Comparison Measurements	2-5
	Differential Operation	2-5
	Voltage Probes	2-5
SECTION 3	CIRCUIT DESCRIPTION	
	Block Diagram Description	3-1
	Detailed Circuit Description	3-1
	Plug-in Logic	3-1
	Input Coupling	3-1
	Input Attenuators	3-2
	Input Protection	3-2
	Preamplifier Stage	3-2
	Common-Mode Rejection	3-3
	Isolation Stage	3-3
	Output Amplifier	3-3
	Trigger Signal Amplifier	3-4
	Vertical Switching and Readout	3-4
SECTION 4	CALIBRATION	
	Services Available	4-1
	Using This Procedure	4-1
	Test Equipment Required	4-1
	Preliminary Control Settings	4-2
	Part I - Performance Check	4-3
	Part II - Adjustment	4-7
SECTION 5	ELECTRICAL PARTS LIST	
SECTION 6	DIAGRAMS	
	Symbols and Reference Designators	
	Schematic Diagrams and Component Board Locations	
SECTION 7	MECHANICAL PARTS LIST	

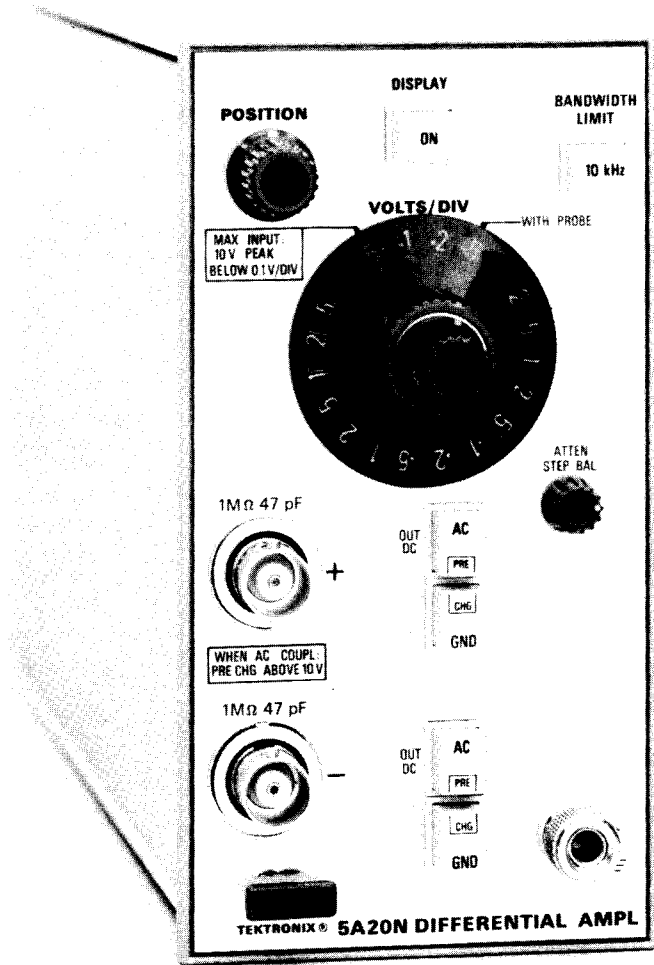
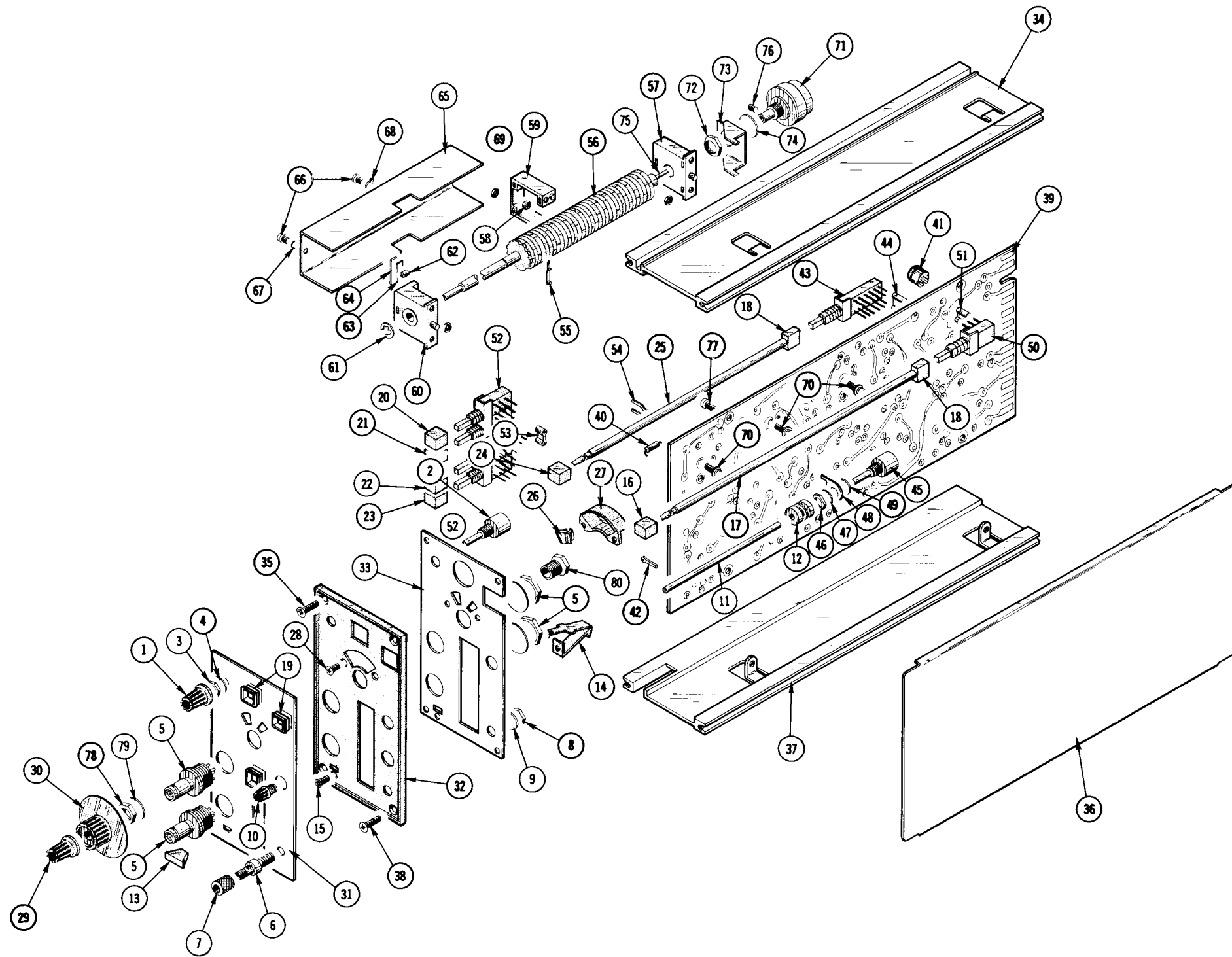

Fig. 1-1. 5A20N Differential Amplifier.

FIGURE 1 EXPLODED



SECTION 1

5A20N SPECIFICATION

Change information, if any, affecting this section will be found at the rear of this manual.

Introduction

The 5A20N Differential Amplifier is a high-gain differential amplifier plug-in for use with Tektronix 5100-series oscilloscopes. The unit features high sensitivity with direct-coupled inputs ($50 \mu\text{V}/\text{DIV}$), and has a high common-mode rejection ratio. An illuminated knob skirt provides deflection factor readout. The unit has a bandwidth capability of DC to one megahertz, and a front-panel pushbutton switch allows reduction of the upper bandwidth limit, thus increasing the signal-to-noise ratio for low-frequency applications.

This instrument will meet the performance requirements listed in Table 1-1 following complete calibration as given in Section 4. The following electrical characteristics apply over an ambient temperature range of 0°C to $+50^{\circ}\text{C}$.

In this manual the word Volts/Div or division refers to major graticule division.

TABLE 1-1
ELECTRICAL CHARACTERISTICS

Characteristic	Performance Requirement	Supplemental Information
Deflection Factor		
Calibrated Range	50 microvolts/division to 5 volts/division	16 steps in a 1-2-5 sequence.
Accuracy	Within 2%.	
Step Attenuator Balance		Adjustable for one division or less trace movement as VOLTS/DIV is rotated throughout its range.
Uncalibrated (Var) Range		At least 2.5:1.
Frequency Response		
Bandwidth (8 Div Reference)		
DC (Direct) Coupled		
1 MHz	DC to at least 1 megahertz.	
10 kHz	DC to \approx 10 kilohertz.	Within 20%.
AC (Capacitive) Coupled		
1 MHz	2 hertz or less to at least 1 megahertz.	
10 kHz	2 hertz or less to \approx 10 kilohertz.	Within 20%.
Step Response (Displayed)		
Aberrations	$\pm 2\%$ or less of pulse amplitude.	
Inputs		
Resistance	1 megohm, within 0.1%.	Time constant normalized for 47 microseconds, within 3% between channels.
Capacitance	\approx 47 picofarads.	

TABLE 1-1 (cont.)

Characteristic	Performance Requirement	Supplemental Information
Maximum Safe Input Voltages		
DC (Direct) Coupled		
50 μ V/Div to 50 mV/Div	10 volts (DC + Peak AC)	
100 mV/Div to 5 V/Div	350 volts (DC + Peak AC)	
AC (Capacitive) Coupled		
50 μ V/Div to 50 mV/Div	350 volts DC (Coupling capacitor pre-charged), 10 volts peak AC.	
100 mV/Div to 5 V/Div	350 volts (DC + Peak AC)	
DC Rejection, AC (Capacitive) Coupled	At least 100,00:1 after 20 minute warmup.	
POSITION Range		At least + and - 10 divisions from graticule center.
Common Mode Rejection		
DC (Direct) Coupled	At least 100 dB, DC to 30 kilohertz at 50 μ V/div and 100 μ V/div, with up to 20-volt peak-to-peak sine wave, decreasing by less than 20 dB/decade on lower sensitivity ranges up to 50 mV/div. From 100 mV/div to 5 V/Div, CMRR is at least 50 dB with up to 100-volt peak-to-peak sine wave. CMRR with two P6060 probes is at least 50 dB at any deflection factor.	
AC (Capacitive) Coupled		
50 μ V/div to 0.5 mV/div	At least 80 dB at 5 kilohertz and above, decreasing to 50 dB at 10 hertz.	
Display Noise (Tanentially Measured)	30 μ V or less	

TABLE 1-2

ENVIRONMENTAL CHARACTERISTICS

Characteristic	Performance Requirement
Temperature	
Operating Range	0°C to +50°C.
Non-operating Range	-55°C to +70°C
Altitude	
Operating Range	To 15,000 feet.
Non-operating Range	To 15,000 feet.
Vibration Range	To 0.015 inch peak-to-peak displacement at 50 cycles per second.
Shock Range	To 30 g's, 1/2 sine, 11 milliseconds duration.

FIGURE 1 EXPLODED (cont)

Fig. & Index No.	Tektronix Part No.	Serial/Model No.		Q t y	Description
		Eff	Disc		
1-52	260-1207-00			2	SWITCH, push--AC-GND
	- - - - -			-	mounting hardware for each: (not included w/switch)
-53	361-0384-00			4	SPACER, switch
-54	344-0154-00			4	CLIP, fuse
-55	131-0604-00			13	CONTACT, electrical
-56	105-0239-00			1	ACTUATOR ASSEMBLY--VOLTS/DIV OR AMPERES/DIV
	- - - - -			-	actuator assembly includes:
	105-0221-00			1	DRUM
-57	401-0056-00			1	BEARING, rear
-58	210-0406-00			6	NUT, hex., 4-40 x 0.188 inch
-59	407-0653-00			1	BRACKET, support
-60	401-0057-00			1	BEARING, front
-61	354-0219-00			1	RING, retainer
-62	214-1127-00			1	ROLLER, detent
-63	214-1139-03			1	SPRING, flat, red
-64	214-1139-02			1	SPRING, flat, green
-65	200-0943-01			1	COVER
	- - - - -			-	mounting hardware: (not included w/cover)
-66	211-0079-00			1	SCREW, 2-56 x 0.188 inch, PHS
-67	210-0001-00			3	WASHER, lock, 0.092 ID x 0.175 inch OD
-68	210-0259-00			1	LUG, solder, #2
-69	210-0405-00			4	NUT, hex., 2-56 x 0.188 inch
	- - - - -			-	mounting hardware: (not included w/actuator assembly)
-70	211-0116-00			6	SCREW, sems, 4-40 x 0.312 inch, PHB
-71	- - - - -			1	RESISTOR, variable
	- - - - -			-	mounting hardware: (not included w/resistor)
-72	220-0495-00			1	NUT, hex., 0.375-32 x 0.438 inch
-73	407-0894-00			1	BRACKET
-74	210-0012-00			1	WASHER, lock, internal, 0.375 ID x 0.50 inch OD
-75	384-0242-00			1	ROD, extension, 7.281 inches
	- - - - -			-	mounting hardware: (not included w/rod)
-76	213-0048-00			1	SETSCREW, 4-40 x 0.125 inch, HSS
	- - - - -			-	mounting hardware: not included w/circuit board assembly)
-77	213-0146-00			4	SCREW, thread forming, #6 x 0.312 inch, PHS
-78	210-0590-00			1	NUT, hex., 0.375-32 x 0.312 inch
-79	210-0012-00			1	WASHER, lock, internal, 0.375 ID x 0.50 inch OD
-80	358-0029-00			1	BUSHING
ACCESSORIES					
	070-1138-00			1	MANUAL, instruction

SECTION 2

OPERATING INSTRUCTIONS

Change information, if any, affecting this section will be found at the rear of this manual.

Introduction

The 5A20N Differential Amplifier Plug-In operates with a Tektronix 5100N-series oscilloscope system. An understanding of the 5A20N operation and capabilities is essential for obtaining best results. This section of the manual gives a brief functional description of the front-panel controls and connectors, a familiarization procedure and general operating information.

PLUG-IN INSERTION AND REMOVAL

The 5A20N is calibrated and ready for use as it is received. It can be installed in any compartment of the 5100N-series Power Supply/Amplifier module, but it is intended for primary use in vertical compartments (the center and left compartments). For X-Y operation, the 5A20N may also be installed in the horizontal (right) compartment (refer to the Oscilloscope System instruction manual for information on X-Y operation).

NOTE

The Power Supply/Amplifier module is designed so that in the absence of DISPLAY ON logic levels from the vertical plug-ins, it will display the output of the unit in the left compartment.

To install, align the upper and lower rails of the 5A20N with the plug-in compartment tracks and fully insert it (the plug-in panel must be flush with the oscilloscope panel). To remove, pull the release latch to disengage the 5A20N from the oscilloscope.

CONTROLS AND CONNECTORS

This is a brief description of the function or operation of the front-panel controls and connectors. More detailed information is given under General Operating Information.

DISPLAY ON

Applies and removes logic levels to the oscilloscope system to enable or disable plug-in operation. Switch is functional only when plug-in is operated in one of the vertical plug-in compartments.

POSITION

Positions display.

BANDWIDTH LIMIT

Allows reduction of the upper bandwidth limit to increase the signal-to-noise ratio for low-frequency applications. Selects upper bandwidth limit at either 1 MHz (button out) or 10 kHz (button in).

VOLTS/DIV

Volts per major graticule division. Selects calibrated deflection factors from 50 $\mu\text{V}/\text{Div}$ to 5 V/Div; 16 steps in a 1-2-5 sequence. Knob skirt is illuminated to indicate deflection factor, and X10 scaling of readout is provided automatically when a 10X coded probe is used.

Variable Volts/Div

Provides uncalibrated, continuously variable deflection factor between calibrated steps; extends range to 12.5 V/Div.

STEP ATTEN BAL

Balances the input amplifier for minimum trace shift throughout the VOLTS/DIV gain-switching range.

Input Coupling Pushbuttons

AC-DC: Button pushed in selects capacitive coupling of signal applied to associated input connector; button out selects direct coupling of input signal.

GND: Disconnects the input signal and provides ground reference to the amplifier input stage.

PRE CHG: Both AC-DC and GND buttons pushed in permits pre-charging of the coupling capacitor to the input signal DC level. Release GND button for measurement.

+ and - Input Connectors

BNC connectors for application of external voltage signals. Connector labeled + indicates that a positive-going signal will cause upward

FIGURE 1 EXPLODED (cont)

Fig. & Index No.	Tektronix Part No.	Serial/Model No.		Q † y	Description
		Eff	Disc		
1-25	384-1059-00			1	SHAFT, extension, 6.581 inches
-26	136-0429-00			2	LIGHT, indicator
-27	337-1430-00			1	SHIELD, light
	- - - - -			-	mounting hardware: (not included w/shield)
-28	213-0254-00			2	SCREW, thread cutting, 2-56 x 0.25 inch, 100° csk, FHS
-29	366-1317-00			1	KNOB, red--VARIABLE
	- - - - -			-	knob includes:
	213-0153-00			1	SETSCREW, 5-40 x 0.125 inch, HSS
-30	366-1295-00			1	KNOB, charcoal-VOLTS/DIV OR AMPERES/DIV
	- - - - -			-	knob includes:
	213-0153-00			2	SETSCREW, 5-40 x 0.125 inch, HSS
-31	333-1405-00			1	PANEL, front
-32	386-1914-00			1	SUBPANEL, front
-33	337-1396-00			1	SHIELD, electrical
-34	426-0725-00			1	FRAME SECTION, top
	- - - - -			-	mounting hardware: (not included w/frame section)
-35	213-0229-00			2	SCREW, thread forming, #6 x 0.375 inch, 100° csk, FHS
-36	337-1399-00			2	SHIELD, side
-37	426-0724-00			1	FRAME SECTION, bottom
	- - - - -			-	mounting hardware: (not included w/frame section)
-38	213-0229-00			2	SCREW, thread forming, #6 x 0.375 inch, 100° csk, FHS
-39	670-1368-00	B010100	B059999	1	CIRCUIT BOARD ASSEMBLY-MAIN
	670-1368-01	B040000		1	CIRCUIT BOARD ASSEMBLY-MAIN
	- - - - -			-	circuit board assembly includes:
	388-1903-00	B010100	B039999	1	CIRCUIT BOARD
	388-1903-01	B040000		1	CIRCUIT BOARD
-40	131-0566-00			1	LINK, terminal connecting
-41	136-0235-00			5	SOCKET, transistor, 6 pin
-42	214-0579-00			4	PIN, test point
-43	260-1208-00			1	SWITCH, push--ON (DISPLAY)
	- - - - -			-	mounting hardware: (not included w/switch)
-44	361-0383-00			2	SPACER, switch
-45	- - - - -			1	RESISTOR, variable
	- - - - -			-	mounting hardware: (not included w/resistor)
-46	210-0583-00			1	NUT, hex., 0.25-32 x 0.312 inch
-47	210-0046-00			1	WASHER, lock, internal, 0.261 ID x 0.40 inch OD
-48	387-0794-00			1	PLATE, mounting
-49	210-0940-00			1	WASHER, flat, 0.35 ID x 0.37 inch OD
-50	260-1209-00			1	SWITCH, push--10 kHz (BANDWIDTH LIMIT)
	- - - - -			-	mounting hardware: (not included w/switch)
-51	361-0385-00			2	SPACER, switch

Operating Instructions—5A20N

+ and – Input
Connectors
(cont)

deflection; connector labeled – indicates that a positive-going signal will cause downward deflection. Connectors include coded-probe input rings for activation of X10 readout.

FIRST TIME OPERATION

Preparation

The first few steps of the following procedure are intended to help place the trace on the screen quickly and prepare the instrument for immediate use. The remainder of the steps demonstrate some of the basic functions of the 5A20N. Operation of other instruments in the system is described in the instruction manuals for those units.

1. Insert the unit all the way into the oscilloscope system plug-in compartment.

2. Turn the oscilloscope Intensity control fully counterclockwise and turn the oscilloscope system Power On. Pre-set the time-base and triggering controls for a 2-millisecond/division sweep rate and automatic triggering.

3. Set the 5A20N front-panel controls as follows:

DISPLAY	ON (readout illuminates)
POSITION	Midrange
BANDWIDTH LIMIT	1 MHz (button out)
VOLTS/DIV	.1 V
STEP ATTEN BAL	Midrange
+ Input Coupling	DC, GND
– Input Coupling	DC, GND

NOTE

About five minutes is sufficient time for warmup when using the 5A20N for short-term DC measurements. For long-term DC measurements using the lower deflection factors, allow at least 15 minutes.

4. Adjust the Intensity control for normal viewing of the trace. The trace should appear near the graticule center.

5. Move the trace two divisions below the graticule centerline with the POSITION control.



If the maximum input voltage rating at the gates of the input FET's is exceeded, the gates are diode-clamped at about + or – 12.5 volts. If the signal source can supply more than 1/16 A, the input protective fuse(s) will open.

6. Apply a 400-millivolt peak-to-peak signal (available at the oscilloscope Calibrator loop) through a test lead or 1X probe to the + input connector.

7. For DC-coupled, single-ended operation, release the GND button associated with the + Input Coupling switch. The display should be square waves four divisions in amplitude, with the bottom of the display at the reference established in step 5. Rotate the Variable Volts/Div control counterclockwise out of its detent position, observing reduction of the display. Return the Variable control to the detent (CAL) position.

8. For AC-coupled, single-ended operation, re-position the display with the POSITION control to place the bottom of the display at the graticule centerline.

9. Push in the AC button and note that the display shifts downward about two divisions to its average level.

10. Disconnect the coaxial cable from the + input connector. Connect a dual input cable to the + and – input connectors, then connect the coaxial cable from the Calibrator to the dual input cable.

11. For AC-coupled differential operation, set the – Input Coupling to AC (AC button in, GND button out). The calibrator signal is now coupled to both inputs as a common-mode signal. A straight line display should be observed, since the common-mode signal is being rejected.

Step Attenuator Balance Adjustment

If this control is not properly adjusted, the CRT zero reference point (trace or spot) will shift vertically due to differential DC imbalance in the amplifier as the VOLTS/DIV switch is rotated throughout its range. The shift is more noticeable on the most sensitive positions.

a. With the instrument operating, ground both the + and – inputs (GND buttons pushed in) and move the trace to graticule center with the POSITION control. Set the VOLTS/DIV switch to 5 V.

b. Adjust the STEP ATTEN BAL control for minimum trace shift as the VOLTS/DIV switch is rotated throughout its range.

Gain Check

Whenever the 5A20N is inserted into a plug-in compartment other than the one in which it was calibrated, the

SECTION 7 MECHANICAL PARTS LIST

5A20N

Fig. & Index No.	Tektronix Part No.	Serial/Model No.		Q † y	Description
		Eff	Disc		
1-1	366-0494-00			1	KNOB, gray--POSITION
	- - - - -			-	knob includes:
	213-0153-00			1	SETSCREW, 5-40 x 0.125 inch, HSS
-2	- - - - -			-	RESISTOR, variable
	- - - - -			-	mounting hardware: (not included w/resistor)
-3	210-0583-00			1	NUT, hex., 0.25-32 x 0.312 inch
-4	210-0940-00			1	WASHER, flat, 0.375 ID x 0.50 inch OD
-5	131-0679-00	B010100	B044726	2	CONNECTOR, receptacle, 3 contact, BNC
	131-0679-02	B044727		2	CONNECTOR, receptacle, 3 contact, BNC
	- - - - -			-	mounting hardware for each:
	220-0497-00	XB044727		1	NUT, plain, hex., 0.095 x 0.562
	210-1039-00	XB044727		1	WASHER, lock, int 0.521 ID x 0.625 OD
	129-0103-00			1	BINDING POST ASSEMBLY
	- - - - -			-	binding post assembly includes:
-6	129-0077-00			1	STUD
-7	129-0103-00			1	CAP
	- - - - -			-	mounting hardware: (not included w/binding post assy)
-8	210-0583-00			1	NUT, hex., 0.25-32 x 0.312 inch
-9	210-0046-00			1	WASHER, lock, internal, 0.261 ID x 0.40 inch OD
-10	366-1036-01			1	KNOB, gray--ATTEN STEP BAL
-11	384-1065-00			1	SHAFT, extension, 3.485 inches long
-12	376-0051-00	B010100	B039999	1	COUPLING
	376-0051-01	B040000		1	COUPLING
	- - - - -			-	coupling includes:
	213-0022-00	B010100	B039999	4	SETSCREW, 4-40 x 0.188 inch, HSS
	213-0048-00	B040000		4	SETSCREW, 4-40 x 0.125 HES SOC STL
	354-0251-00			2	RING
	376-0049-00			1	COUPLING
-13	366-1286-00	B010100	B039999	1	KNOB, latch
	366-1286-03	B040000		1	KNOB, latch
	214-1840-00	XB040000		1	PIN, knob securing
-14	214-1513-00	B010100	B039999	1	LATCH, plug-in
	214-1513-01	B040000		1	LATCH, plug-in
	- - - - -			-	mounting hardware: (not included w/latch)
-15	213-0254-00			1	SCREW, thread forming, 2-56 x 0.25 inch, 100 deg csk, FHS
-16	366-1257-15			1	KNOB, gray--10 kHz (BANDWIDTH LIMIT)
-17	384-1058-00			1	SHAFT, extension, 7.781 inches long
-18	366-1292-00			2	PUSHBUTTON, gray
-19	426-0681-00			6	FRAME, pushbutton
-20	366-1257-11			1	PUSHBUTTON, gray--AC (+)
-21	366-1257-12			1	PUSHBUTTON, gray--GND (+)
-22	366-1257-11			1	PUSHBUTTON, gray--AC (-)
-23	366-1257-12			1	PUSHBUTTON, gray--GND (-)
-24	366-1257-14			1	PUSHBUTTON, gray--ON (DISPLAY)

amplifier gain may be checked and, if necessary, adjusted. See the Calibration Procedure in this manual for complete instructions.

GENERAL OPERATING INFORMATION

Applying Signals

When measuring DC voltages, use the largest deflection factor (5 V/Div) when first connecting the 5A20N to an unknown voltage source. If the deflection is too small to make the measurement, switch to a lower deflection factor. If the input stage is overdriven, a large amount of current might flow into the input and open the protective fuse. See CAUTION after item 6 of the First Time Operation.

Pre-charging. When only the AC component of a signal having both AC and DC components is to be measured, use the Input Coupling switches (AC and GND pushbuttons) to take advantage of the pre-charging circuit incorporated in the unit. The pre-charging circuit permits charging the coupling capacitor to the DC source voltage when the AC and GND buttons are pressed in. The procedure for using this circuit is as follows:

a. Before connecting the 5A20N to a signal containing a DC component, push in the AC and GND buttons. Then connect the input to the circuit under test.

b. Wait about one second for the coupling capacitor to charge.

c. Remove the ground from the coupling capacitor (GND button out). The display will remain on-screen and the AC component can be measured in the usual manner.

The above procedure should be followed whenever a signal having a different DC level is connected.



If the 5A20N input is connected to a large DC voltage source without using the pre-charge provision, the peak charging current (into a 0.1 μ F capacitor) will be limited only by the internal resistance of the signal source, and this source may be damaged.

Signal Input Connectors

When connecting signals to the + and – input connectors on the 5A20N, consider the method of coupling that will be used. Sometimes unshielded test leads can be used to connect the 5A20N to a signal source, particularly when a high level, low-frequency signal is monitored at a low

impedance point. However, when any of these factors is missing, it becomes increasingly important to use shielded signal cables. In all cases, the signal-transporting leads should be kept as short as practical.

When making single-ended input measurements (conventional amplifier operation), be sure to establish a common ground connection between the device under test and the 5A20N. The shield of a coaxial cable is normally used for this purpose.

In some cases, differential measurements require no common ground connection,¹ and therefore are less susceptible to interference by ground-loop currents. Some problems with stray magnetic coupling into the signal-transporting leads can also be minimized by using a differential rather than a single-ended measurement. These considerations are discussed later in this section under Differential Operation.

It is always important to consider the signal source loading (and resulting change in the source operating characteristics) due to the signal-transporting leads and the input circuit of the 5A20N. The circuit at the input connectors can normally be represented by a 1 megohm resistance to ground paralleled by about 47 pF. A few feet of shielded cable (20 to 40 pF per foot) may increase the parallel capacitance to 100 pF or more. In many cases, the effects of these resistive and capacitive loads may be too great and it may be desirable to minimize them through the use of an attenuator probe.

Attenuator probes not only decrease the resistive capacitive loading of a signal source, but also extend the measurement range of the 5A20N to include substantially higher voltages. Passive attenuator probes having attenuation factors of 10X, 100X, and 1000X, as well as other special-purpose types, are available through your Tektronix Field Engineer or Field Office.

Some measurement situations require a high resistance input to the 5A20N with very little source loading or signal attenuation. In such situations, a passive attenuator probe cannot be used. However, this problem may be solved by using a FET Probe or the high impedance input provision of the 5A20N.

¹The DC plus AC voltages on the test points (with respect to the chassis potential of the 5A20N) should be limited to the levels listed in Section 1 under Maximum Common-Mode Input Voltage characteristics. Higher levels will degrade the common-mode rejection ratio and exceed the input voltage rating of the unit.

High Impedance Input

In the 50 mV through 50 μ V positions of the VOLTS/DIV switch, where the input attenuator is not used, the internal gate return resistors alone establish the 1 megohm input resistance. The removal of the strap from the circuit board disconnects these resistors from ground and permits the input FET gates to float, providing a very high input impedance (see Fig. 4-1 in the Calibration section for location of the strap). The signal source must then provide a DC path for the FET gate current.

The input signal must be kept to relatively low amplitudes, since the deflection factor is restricted to 50 mV/div through 50 μ V/div, and DC coupling must be used.

NOTE

In the 0.1 V to 5 V range of the VOLTS/DIV switch, the input impedance is paralleled by the resistors in the attenuator. When the link is removed, the attenuation ratio is affected, causing the deflection factors in this range to be incorrect. To determine the deflection factor, check the deflection with an input signal of known amplitude.

The signal source impedance is an important factor, since gate current will produce a DC offset. For example, a 100 picoampere gate current through 10 megohms produces a one-millivolt offset, which may result in significant error where small voltages are of concern.

The high frequency response will also depend upon the signal source impedance, since various shunt capacitances between the source and the input gate must charge and discharge through that impedance.

Display Polarity

Single-ended signals applied to the + input connector produce a display in phase with the input signal. Signals applied to the - input connector will be inverted.

A similar polarity relationship exists for differentially applied signals, but pertains to the direction of voltage change at one input with respect to the other, rather than with respect to chassis potential.

Deflection Factor

The amount of trace deflection produced by a signal is determined by the signal amplitude, the attenuation factor (if any) of the probe, the setting of the VOLTS/DIV switch, and the setting of the Variable control. The cali-

brated deflection factors are indicated by the VOLTS/DIV switch only when the Variable control is rotated fully clockwise into the detent position.

The range of the Variable control is at least 2.5:1. It provides uncalibrated deflection factors covering the full range between the fixed settings of the VOLTS/DIV switch. The control can be set to extend the deflection factor to at least 12.5 volts/division.

To reduce noise and obtain a more usable display when the VOLTS/DIV switch is set to the more sensitive positions, set the BANDWIDTH LIMIT switch to 10 kHz if this limit does not appreciably distort the desired features of the signal under observation. Fig. 2-1 shows the improvement in a displayed one-kilohertz signal when the BANDWIDTH LIMIT switch is used.

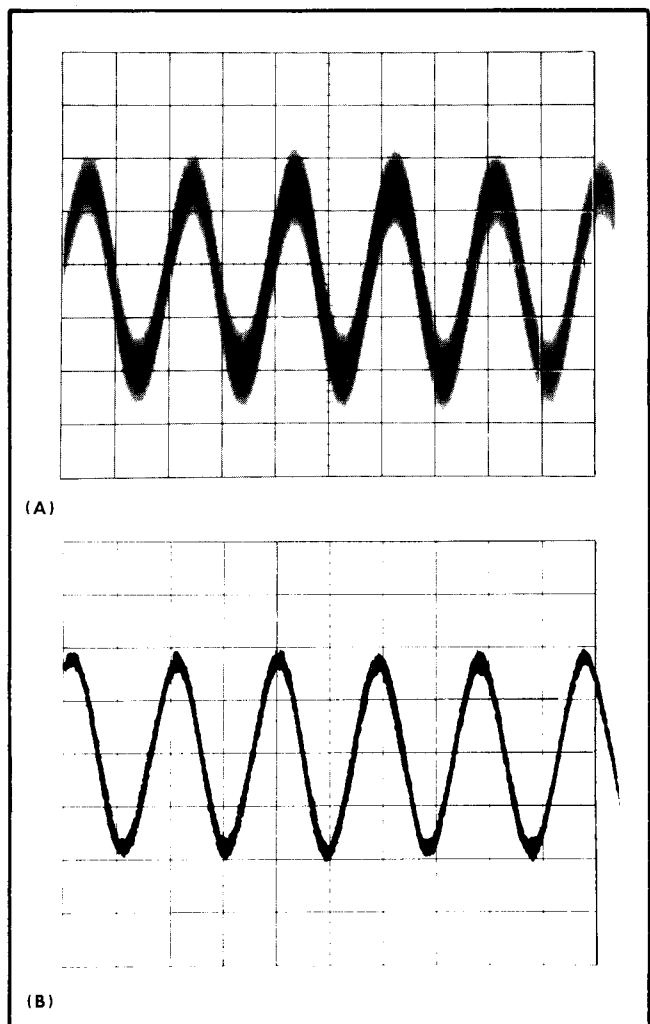
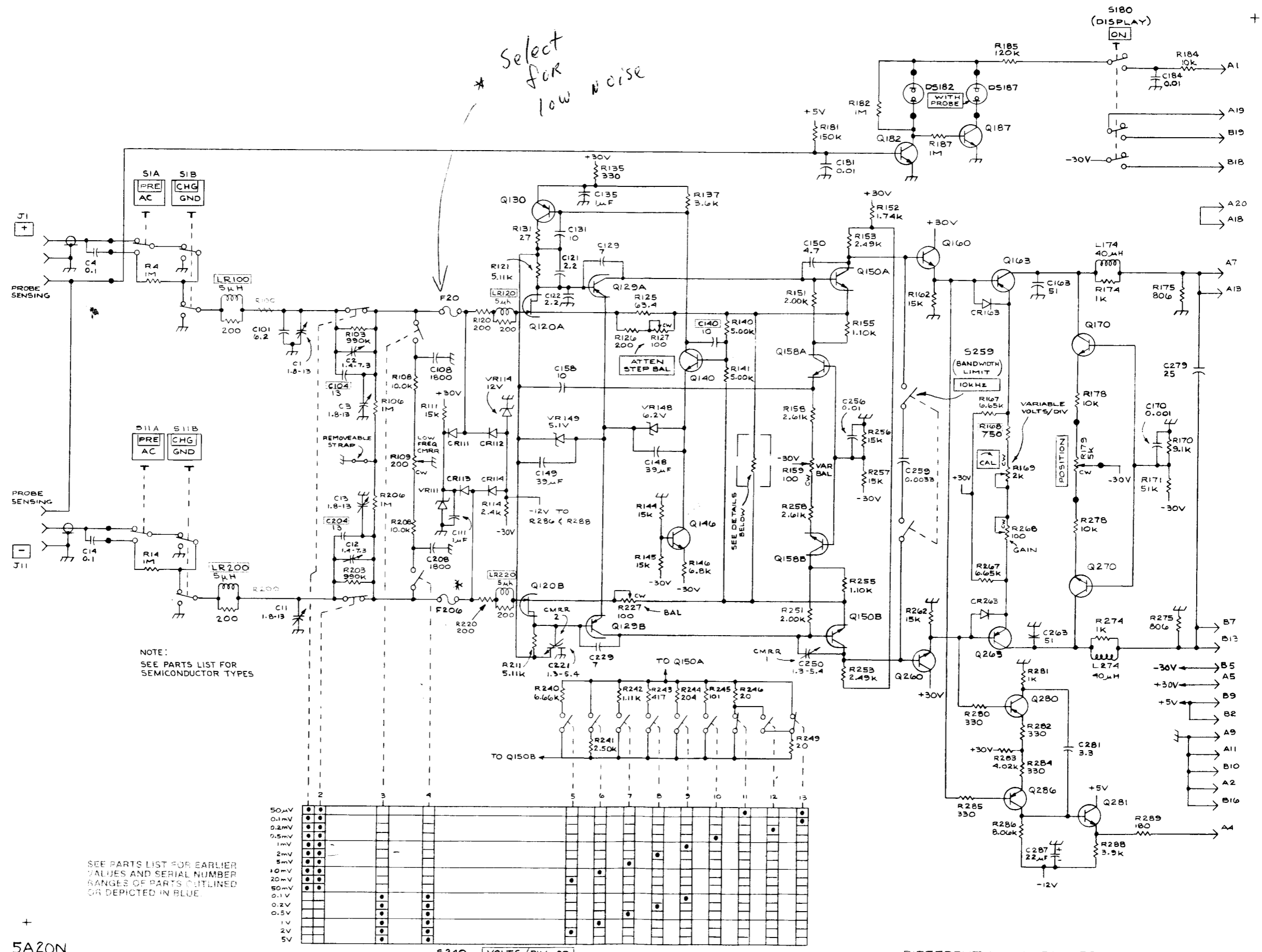

Fig. 2-1. Improving signal-to-noise ratio by setting bandwidth; (A) signal applied with the BANDWIDTH LIMIT switch set to 1 MHz. (B) same signal with the BANDWIDTH LIMIT switch set to 10 kHz.



* Select for low noise

NOTE:
SEE PARTS LIST FOR SEMICONDUCTOR TYPES

SEE PARTS LIST FOR EARLIER VALUES AND SERIAL NUMBER RANGES OF PARTS OUTLINED OR DEPICTED IN BLUE.

50μV												
0.1mV												
0.2mV												
0.5mV												
1mV												
2mV												
5mV												
10mV												
20mV												
50mV												
0.1V												
0.2V												
0.5V												
1V												
2V												
5V												

5A20N

Voltage Comparison Measurements

Some applications require deflection factors other than the fixed values provided by the VOLTS/DIV switch. One such application is comparison of signal amplitudes by ratio rather than by absolute voltage. To accomplish this, apply a reference signal to either input of the 5A20N, and set the VOLTS/DIV switch and Variable control so that the reference display covers the desired number of graticule divisions. Do not change this setting of the Variable control throughout the subsequent comparisons. The settings of the VOLTS/DIV switch can be changed, however, to accommodate large ratios. In doing so, regard the numbers which designate the switch positions as ratio factors rather than voltages.

Differential Operation

Single-ended measurements often yield unsatisfactory results because of interference resulting from ground-loop currents between the 5A20N and the device under test. In other cases, it may be desirable to eliminate a DC voltage by means other than the use of a DC-blocking capacitor, which could limit the low-frequency response.

These limitations of single-ended measurements are effectively eliminated using differential measurements. Differential measurements are made by connecting each input (+ input and – input) to selected points in the test circuit. Since the chassis of the 5A20N need not be connected in any way to the test circuit, there are few limitations to the selection of these test points. In any case, do not exceed the maximum safe input voltages listed in Section 1.

Both Input Coupling switches should be set to the same position, AC or DC, depending on the method of signal coupling required.

Only the voltage difference between two signals is amplified and displayed in differential measurements, while the common-mode signals (common in amplitude, frequency, and phase) are rejected. See Fig. 2-2.

The ability of the 5A20N to reject common-mode signals is indicated by the common-mode rejection ratio (CMRR). CMRR is at least 100,000:1 at the input connectors for the smaller deflection factors (50 μ V/DIV and 100 μ V/DIV) when signals between DC and 30 kHz are DC coupled to the inputs. To illustrate this characteristic, assume that a single-ended input signal consists of an unwanted 60 Hz signal at 1 volt peak to peak, plus a desired signal at 1 mV peak to peak. If an attempt is made to display the described signal (single-ended measurement) at

.2 mV/DIV, the 60 Hz signal will produce a deflection equivalent to 5000 divisions and the 1 mV signal will be lost.

If the same 1 mV signal is measured differentially with the 60 Hz signal common to both inputs, no more than one part in 100,000 of the common-mode signal will appear in the display. The desired signal will produce a display of 5 divisions, with not more than 0.1 division of display produced by the common-mode signal (CMRR not specified when residual display is 0.1 division or less).

There are a number of factors which can degrade common-mode rejection. The principal requirement for maximum rejection is for the common-mode signal to arrive at the input FET gates in precisely the same form. A difference of only 0.01% in the attenuation factors of the input attenuators may reduce the rejection ratio to 10,000:1. Likewise, any difference in source impedance at the two points in the source under test will degrade the rejection ratio. Attenuator probes which do not have adjustable R and C may reduce the rejection ratio to 100:1 or less.

Outside influences such as magnetic fields can also degrade the performance, particularly when low level signals are involved. Magnetic interference may be minimized by using identical signal-transporting leads to the two inputs and twisting the two leads together over as much of their length as possible.

Voltage Probes

In general, probes offer the most convenient means of connecting a signal to the input of the 5A20N. Tektronix probes are shielded to prevent pickup of electrostatic interference. A 10X attenuator probe offers a high input impedance and allows the circuit under test to perform very close to normal operating conditions. See your Tektronix, Inc., catalog for characteristics and compatibility of probes for use with this system.

Differential Measurement. The following adjustment procedure is recommended when preparing to use two Tektronix P6023 probes for differential measurement. (This probe type does not have the coding feature to be discussed later.)

- a. Connect one probe for DC-coupled single-ended input. Obtain a triggered display of an appropriate square wave, such as that from a calibrator or square-wave generator. Adjust the probe DC Atten Calibration control for correct deflection sensitivity, then compensate the probe square-wave response using the AC Fine Comp adjust and the AC Coarse Comp adjust if necessary.

5A20 PARTS LOCATION GRID

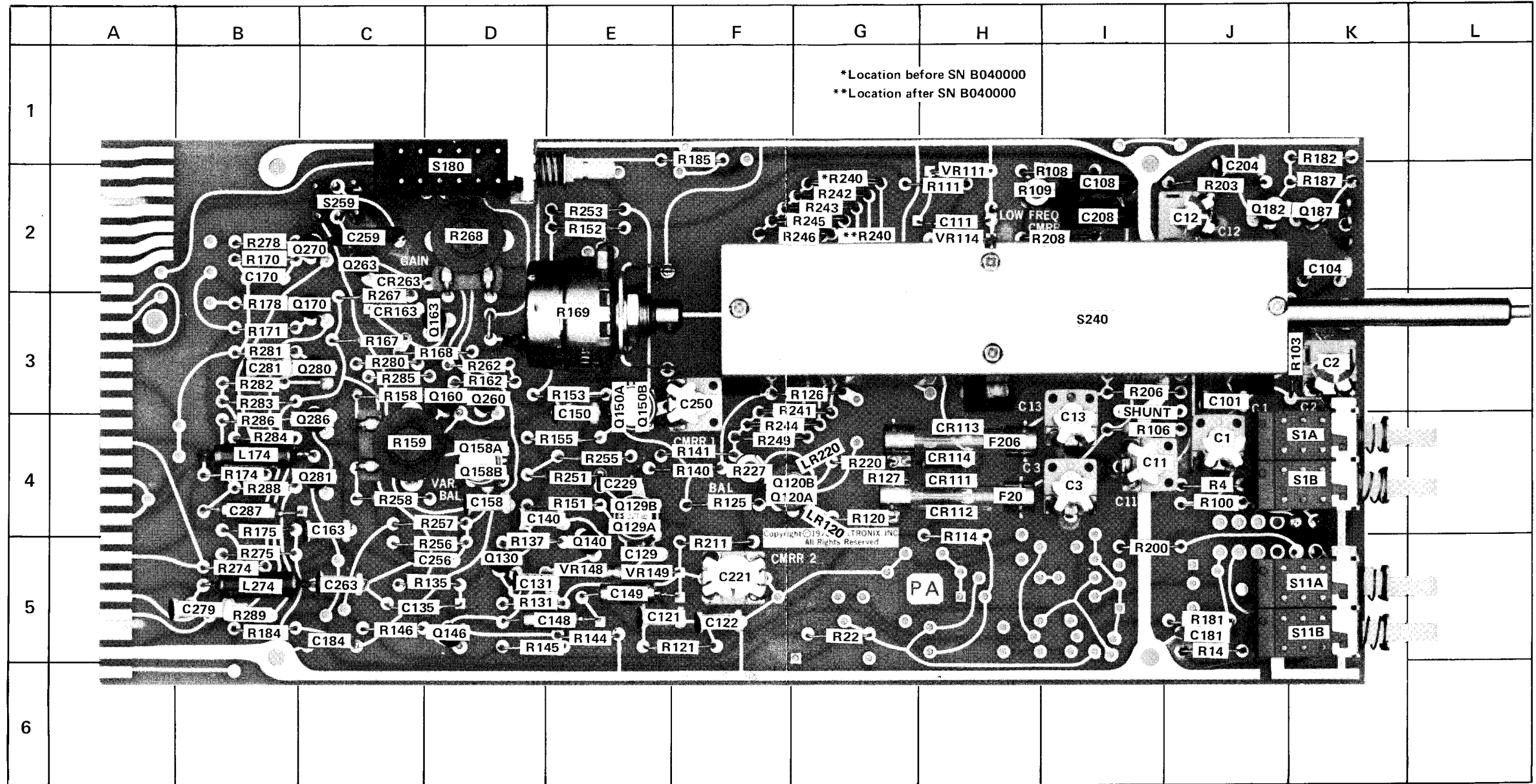

CKT NO	GRID LOC	CKT NO	GRID LOC	CKT NO	GRID LOC	CKT NO	GRID LOC	CKT NO	GRID LOC	CKT NO	GRID LOC	CKT NO	GRID LOC	CKT NO	GRID LOC	CKT NO	GRID LOC	CKT NO	GRID LOC	CKT NO	GRID LOC	CKT NO	GRID LOC	CKT NO	GRID LOC	CKT NO	GRID LOC			
C1	J-4	C140	E-4	C259	C-2	CR111	H-4	F20	H-4	L174	B-4	Q120A,B	F-4	Q280	C-3	R4	J-4	R135	D-5	R168	D-3	R208	I-2	R256	D-5	R286	B-4	S1A	K-4	
C2	K-3	C148	D-5	C263	C-5	CR112	H-4	F206	H-4	L274	B-5	Q129A,B	E-4	Q281	C-4	R14	J-5	R137	D-5	R169	E-3	R211	F-5	R257	D-4	R288	B-4	S1B	K-4	
C3	I-4	C149	E-5	C279	B-5	CR113	H-4					Q130	D-5	Q286	C-4	R100	J-4	R140	F-4	R170	B-2	R220	G-4	R258	C-4	R289	B-5	S11A	K-5	
C11	I-4	C150	E-4	C281	B-3	CR114	H-4			LR120	G-4	Q140	E-5			R103	K-3	R141	F-4	R171	B-3	R227	F-4	R262	D-3			S11B	K-5	
C12	J-2	C158	D-4	C287	B-4	CR163	C-3			LR220	G-4	Q146	D-5			R106	I-4	R144	E-5	R174	B-4	R240	G-2	R267	C-3			S180	D-2	
C13	I-4	C163	C-4			CR263	C-2					Q150A,B	E-4			R108	I-2	R145	D-5	R175	B-4	R241	G-3	R268	D-2			S240	I-3	
C101	J-3	C170	B-2			VR111	H-2					Q158A,B	D-4			R109	I-2	R146	C-5	R178	B-3	R242	G-2	R274	B-5			S259	C-2	
C104	K-2	C181	J-5			VR114	H-2					Q160	D-3			R111	H-2	R151	E-4	R181	J-5	R243	G-2	R275	B-5					
C108	I-2	C184	C-5			VR148	E-5					Q163	D-3			R114	H-5	R152	E-2	R182	K-1	R244	F-4	R278	B-2					
C111	H-2	C204	J-1			VR149	E-5					Q170	C-3			R120	G-4	R153	E-3	R184	B-5	R245	G-2	R280	C-3					
C121	E-5	C208	I-2									Q182	J-2			R121	F-5	R155	E-4	R185	F-1	R246	G-2	R281	B-3					
C122	F-5	C221	F-5									Q187	K-2			R125	F-4	R158	C-3	R187	K-2	R249	F-4	R282	B-3					
C129	E-5	C229	E-4									Q260	D-3			R126	G-3	R159	C-4	R200	I-5	R251	E-4	R283	B-3					
C131	D-5	C250	F-3									Q263	C-2			R127	G-4	R162	D-3	R203	J-2	R253	E-2	R284	B-4					
C135	D-5	C256	D-5									Q270	C-2			R131	D-5	R167	C-3	R206	I-3	R255	E-4	R285	C-3					

Operating Instructions—5A20N

b. Connect a second probe for DC-coupled operation. Apply the square wave to both probes at 100 volts peak to peak. Free run the sweep and adjust the DC Atten Calibration of the second probe for maximum low frequency cancellation (minimum signal amplitude, or elimination of the two-trace appearance).

c. Adjust the AC Fine Comp and AC Coarse Comp, if necessary, of the second probe to minimize the amplitude of the differential pulses on the displayed trace.

d. The above procedure matches the probes for use at any sensitivity which employs the particular 5A20N input attenuator (1X or 100X) used in steps b and c. When it is necessary to use the other input attenuator, steps b and c should be repeated for that attenuator.

e. When examining a small differential signal in the presence of relatively large common-mode components, fine adjustment of probe CMRR may be made by temporarily connecting both probes to either of the two signal sources.

f. Movement of the probes should be kept to a minimum after the adjustment.

Coded Probes. The 5A20N is designed for compatibility with coded probes, such as the Tektronix P6060 or P6052 1X/10X Passive Probe. The + and – input connectors have an outer ring to which the coding ring on the probe connector makes contact. This type of probe allows the vertical deflection factor indicated by the readout to correspond with the actual voltage at the probe tip, eliminating the need to consider the attenuation factor when measuring the signal amplitude on the graticule scale.

Attenuation on the P6052 probe is selected by a sliding collar on the probe barrel. When the collar is pulled back (away from the probe tip), 1X attenuation is selected; when the collar is pushed forward (nearest the probe tip), 10X attenuation is selected. Input resistance for 1X attenuation is 1 megohm; for 10X, 10 megohms. Probe compensation is obtained in the usual manner (see probe manual for details).

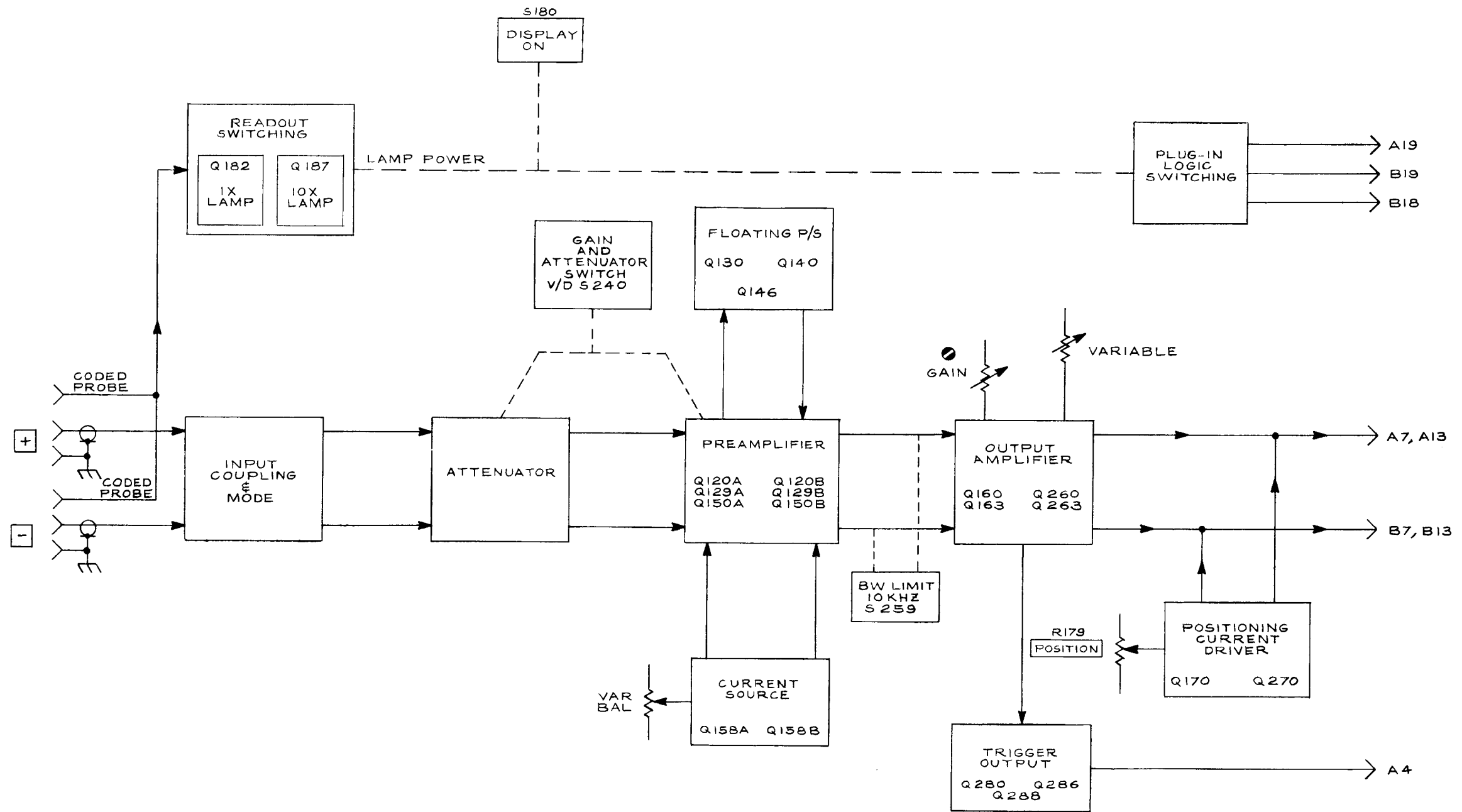

5A20N BLOCK DIAGRAM

Ⓐ

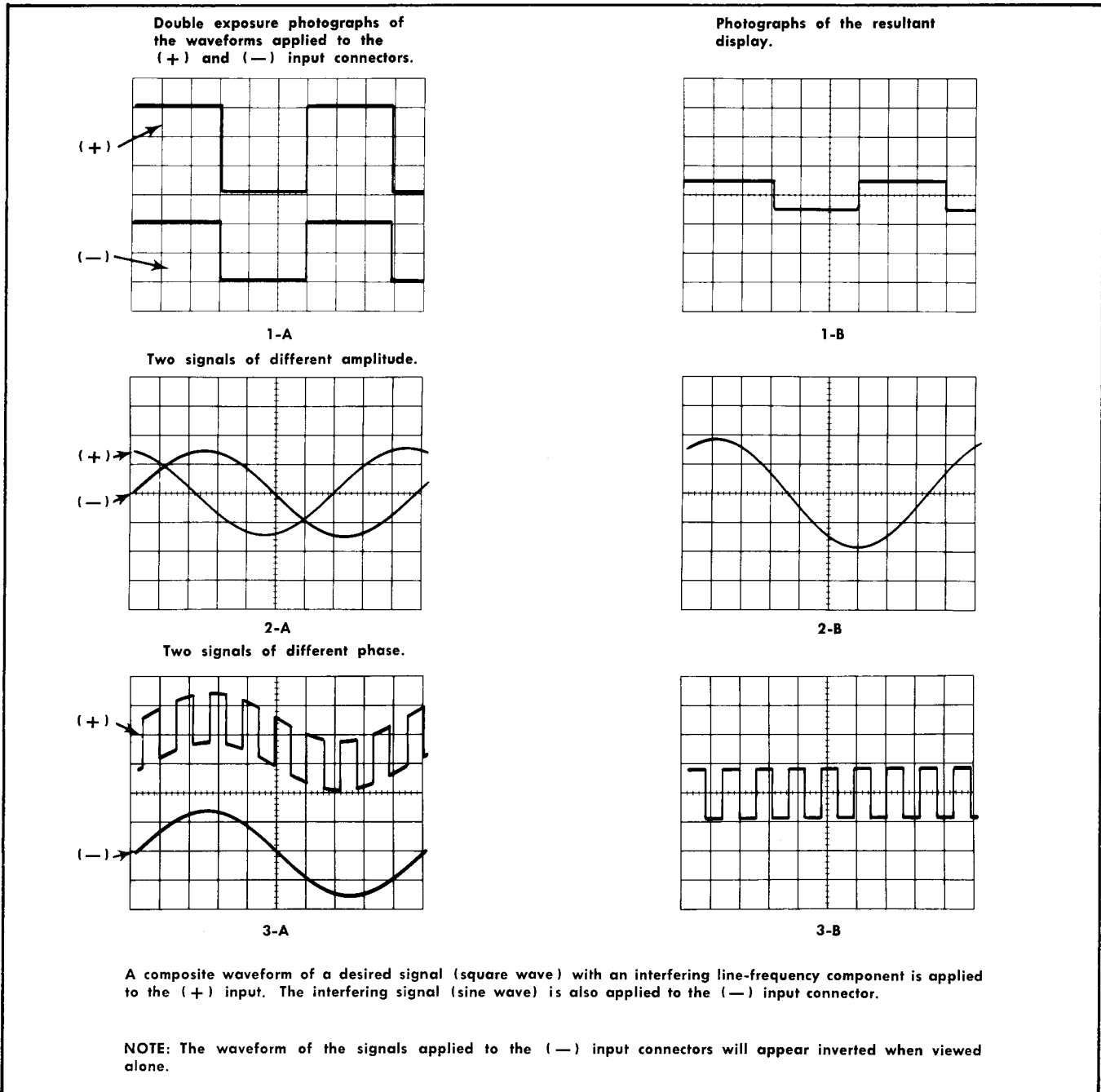

Fig. 2-2. Three examples of differential applications.

SECTION 6

DIAGRAM AND CIRCUIT BOARD ILLUSTRATION

Symbols and Reference Designators

Electrical components shown on the diagrams are in the following units unless noted otherwise:

Capacitors = Values one or greater are in picofarads (pF).
 Values less than one are in microfarads (μ F).
 Resistors = Ohms (Ω)

Symbols used on the diagrams are based on USA Standard Y32.2-1967.

Logic symbology is based on MIL-STD-806B in terms of positive logic. Logic symbols depict the logic function performed and may differ from the manufacturer's data.

The following special symbols are used on the diagrams:

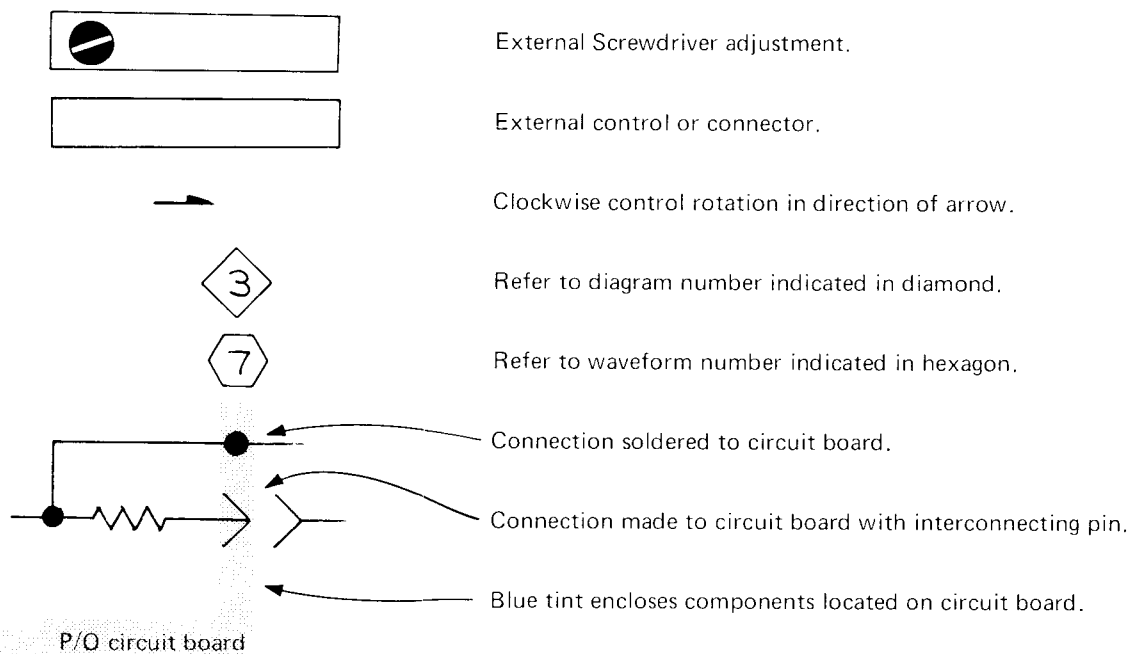

The following prefix letters are used as reference designators to identify components or assemblies on the diagrams.

A	Assembly, separable or repairable (circuit board, etc.)	LR	Inductor/resistor combination
AT	Attenuator, fixed or variable	M	Meter
B	Motor	Q	Transistor or silicon-controlled rectifier
BT	Battery	P	Connector, movable portion
C	Capacitor, fixed or variable	R	Resistor, fixed or variable
CR	Diode, signal or rectifier	RT	Thermistor
DL	Delay line	S	Switch
DS	Indicating device (lamp)	T	Transformer
F	Fuse	TP	Test point
FL	Filter	U	Assembly, inseparable or non-repairable (integrated circuit, etc.)
H	Heat dissipating device (heat sink, heat radiator, etc.)	V	Electron tube
HR	Heater	VR	Voltage regulator (zener diode, etc.)
J	Connector, stationary portion	Y	Crystal
K	Relay		
L	Inductor, fixed or variable		

SECTION 3

CIRCUIT DESCRIPTION

Change information, if any, affecting this section will be found at the rear of this manual.

Introduction

This section of the manual contains an electrical description of the circuits in the 5A20N Differential Amplifier unit. Complete schematic diagrams and an overall block diagram of the unit are given on pullout pages at the back of this manual.

BLOCK DIAGRAM DESCRIPTION

When the DISPLAY ON button is pressed, a logic level is applied to the oscilloscope to enable 5A20N operation (switch function is limited to operation in a vertical compartment), and the front-panel readout lamp illuminates to indicate the ON mode.

Signals applied to the + and – input connectors can be passed directly to the attenuators (DC coupled) or they can be capacitively (AC) coupled to block the DC component of the signal. The GND switch disconnects DC-coupled signals and applies a reference ground to the preamplifier input; for AC-coupled signals, the coupling capacitor is allowed to pre-charge to the DC level of the signal, preventing a damaging current surge when the ground is removed.

The input attenuators are frequency-compensated voltage dividers. 1X attenuation is provided for positions 50 μ V to 50 mV of the VOLTS/DIV switch, and 100X attenuation is provided for positions 0.1 V to 5 V. Balance to a low-frequency common-mode signal between the attenuators of the two inputs is set by adjustment of the LF CMRR potentiometer.

From the input attenuators, the signal is passed directly to the preamplifier. The inputs to the preamplifier are fuse- and diode-protected. The preamplifier consists of two identical operational amplifiers connected in a differential configuration. Common-mode signals between ground and the two inputs are rejected, due to a bootstrapped floating power supply that moves with the common-mode signal to maintain constant operating characteristics of the active devices. The difference between the two inputs is amplified. The VOLTS/DIV switch changes the value of the common source/emitter resistor between the two sides, thus changing the gain for various deflection factors. The output of the preamplifier stage is a push-pull signal, opposite in polarity to that applied to the input.

The BANDWIDTH LIMIT 10 kHz switch places a capacitor across the two output lines to reduce the bandwidth and thus limit the noise referred to the input. The signal is then passed through an emitter-follower isolation stage to the output amplifier.

The output differential amplifier is operated push-pull, presenting a signal to the output terminals that is of the same polarity as that applied to the preamplifier input. Emitter degeneration produced by the Variable Volts/Div and Gain controls provides a means of varying the gain of the 5A20N. A positioning-current driver is connected to the output lines to alter the quiescent trace position.

A triggering signal is tapped from the emitter-follower isolation stage, amplified and made available to an associated time-base plug-in unit. Triggering signal amplitude is about 0.25 volt per displayed division.

DETAILED CIRCUIT DESCRIPTION

Plug-In Logic

When the DISPLAY ON button, S180, is pressed, a logic level is applied to the electronic switching circuit in the oscilloscope to enable plug-in operation. Power is applied to illuminate the front-panel knob-skirt readout lamp, indicating the ON mode.

Input Coupling

Signals applied to the front-panel + and – input connectors may be capacitive coupled (AC), direct coupled (DC), or internally disconnected (GND). Input coupling is selected by means of two pushbutton switches at each input, S1A and S1B for the + input and S11A and S11B for the – input.

Assuming that a signal is applied to the + input, when both buttons are out the applied signal is passed directly to the attenuators. When the AC button is pressed, C4 is placed in the circuit to couple signals of about two hertz (–3 dB point) and higher to the attenuator. This capacitor blocks any DC component of the signal. When the GND button is pressed, a ground reference is provided to the input of the amplifier without the need to remove the applied signal from the input connector.

MAIN Circuit Board Assembly (cont)

Ckt. No.	Tektronix Part No.	Serial/Model No. Eff	No. Disc	Description		
Resistors (cont)						
R255	321-0197-00		1.1 k Ω	1/8 W	Prec	1%
R256	321-0306-00		15 k Ω	1/8 W	Prec	1%
R257	321-0306-00		15 k Ω	1/8 W	Prec	1%
R258	321-0233-00		2.61 k Ω	1/8 W	Prec	1%
R262	315-0153-00		15 k Ω	1/4 W		5%
R267	321-0272-00		6.65 k Ω	1/8 W	Prec	1%
R268	311-1120-00		100 Ω , Var			
R274	316-0102-00		1 k Ω	1/4 W		
R275	321-0184-00		806 Ω	1/8 W	Prec	1%
R278	315-0103-00		10 k Ω	1/4 W		5%
R280	315-0331-00		330 Ω	1/4 W		5%
R281	316-0102-00		1 k Ω	1/4 W		
R282	315-0331-00		330 Ω	1/4 W		5%
R283	321-0251-00		4.02 k Ω	1/8 W	Prec	1%
R284	315-0331-00		330 Ω	1/4 W		5%
R285	315-0331-00		330 Ω	1/4 W		5%
R286	321-0280-00		8.06 k Ω	1/8 W	Prec	1%
R288	316-0392-00		3.9 k Ω	1/4 W		
R289	316-0181-00		180 Ω	1/4 W		
Switches						
Wired or Unwired						
S1A	260-1207-00		Pushbutton	PRE AC		
S1B				CHG GND		
S11A	260-1207-00		Pushbutton	PRE AC		
S11B				CHG GND		
S180	260-1209-00		Pushbutton	DISPLAY ON		
S240 ¹	* 105-0239-00		Cam Actuator Assy	VOLTS/DIV OR AMPERES/DIV		
S250	260-1208-00		Pushbutton	BANDWIDTH LIMIT 10 kHz		

¹ See Mechanical Parts List for replacement parts.

Circuit Description—5A20N

NOTE

When DC levels (above 10 volts) are to be blocked by AC coupling, both the AC and GND buttons should be pressed in (PRE CHG) while input connections are made or broken, or when voltage levels are changed. This will allow the coupling capacitor to charge without blowing the input fuses or overdriving the amplifier.

Input Attenuators

The input attenuators are frequency-compensated voltage dividers and provide 100X attenuation in positions 0.1 to 5 of the VOLTS/DIV switch. At DC and for low-frequency signals, the dividers are essentially resistive (attenuation ratio determined by the resistance ratio). Balance to a low-frequency common-mode signal between the attenuators of the two inputs is set by adjustment of R109, LF CMRR. At higher frequencies, the capacitive reactance becomes effective and the attenuation ratio is determined by the impedance ratio.

In addition to providing constant 100X attenuation at all frequencies within the bandwidth capabilities of the instrument, the input attenuators maintain a constant input RC characteristic (one megohm paralleled by about 47 pF) for settings 0.1 to 5 of the VOLTS/DIV switch.

Input Protection

Input protection consists of fuses F20, F206 and diodes CR111, CR112, CR113, and CR114. If the signal should reach a level sufficient to forward bias one of the protection diodes (a potential greater than about 12.5 volts), current will be conducted through that diode, protecting the input FET's. If that current should exceed the I^2T rating of the fuse, the protective fuse(s) will open. If the signal source is not able to supply enough current to open the fuse, damage to the signal source may result.

Preamplifier Stage

The preamplifier consists of two identical operational amplifiers, connected in a differential configuration. Fig. 3-1 shows a simplified block diagram of the Preamp.

The operational amplifiers are composed of Q120A, Q129A and Q150A on one side, and Q120B, Q129B and Q150B on the other side. Q120A and Q120B provide a voltage follower input to output transistors Q150A and Q150B. Total gain of the stage is determined by the resistance between the two sides of the amplifier, and R153 and R253 (the signal current path in Fig. 3-1).

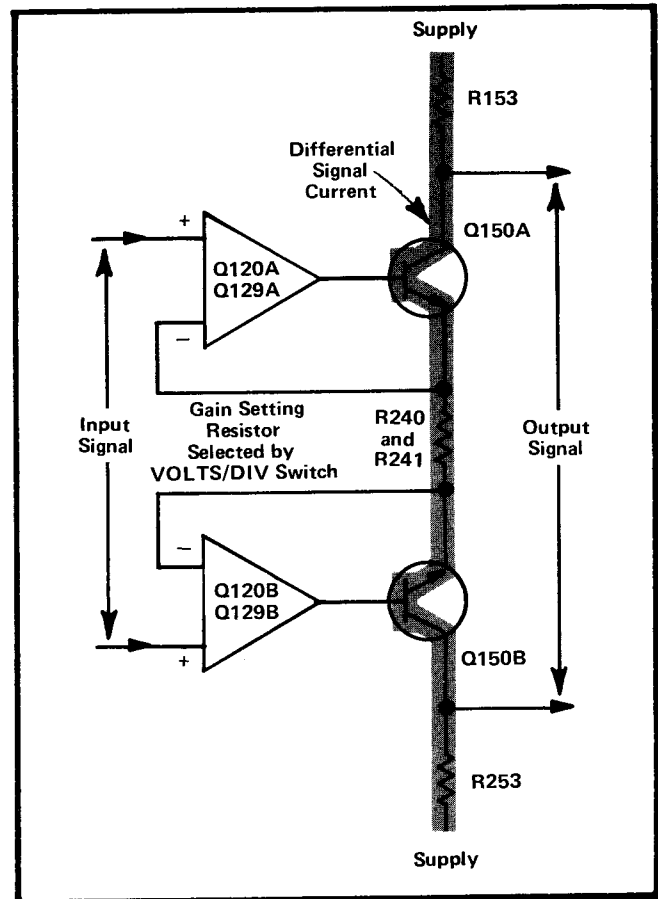

Fig. 3-1. Input Preamp detailed block diagram showing signal current paths.

Quiescently, the two sides of the amplifier are balanced so that there is no current through R240. When a differential signal is applied to the gates of Q120A and Q120B, the signal current is developed through the parallel combination of the gain-setting resistor R240-R249 and R140-R141. Conduction of Q150A and Q150B is changed by the amount of this current, developing the output voltage across R153 and R253. The output is a push-pull signal, opposite in polarity to the signal applied to the inputs. The value of R240-R249 is selected by the VOLTS/DIV switch, S240, to determine the gain.

To minimize trace shift as different vertical deflection factors are selected, the outputs at Q150A and Q150B collectors are DC balanced at equal potentials so that the voltage across the gain-setting resistors is zero at all settings of the VOLTS/DIV switch. This DC balancing is achieved by adjusting R227, Coarse Bal, and R127, STEP ATTEN BAL, with the gates of Q120A and Q120B effectively tied together and the VOLTS/DIV switch set to 1 mV.

R159, Var Bal, located in the emitter circuit of constant-current source transistors Q158A and Q158B, is adjusted

MAIN Circuit Board Assembly (cont)

Ckt. No.	Tektronix Part No.	Serial/Model No. Eff	No. Disc	Description		
Resistors (cont)						
R153	321-0231-00		2.49 k Ω	1/8 W	Prec	1%
R155	321-0197-00		1.1 k Ω	1/8 W	Prec	1%
R158	321-0233-00		2.61 k Ω	1/8 W	Prec	1%
R159	311-1120-00		100 Ω , Var			
R162	315-0153-00		15 k Ω	1/4 W		5%
R167	321-0272-00		6.65 k Ω	1/8 W	Prec	1%
R168	321-0182-00	B010100 B039999	768 Ω	1/8 W	Prec	1%
R168	321-0181-00	B040000	750 Ω	1/8 W	Prec	1%
R169	311-1121-00		2 k Ω , Var			
R170	315-0912-00		9.1 k Ω	1/4 W		5%
R171	315-0513-00		51 k Ω	1/4 W		5%
R174	316-0102-00		1 k Ω	1/4 W		
R175	321-0184-00		806 Ω	1/8 W	Prec	1%
R178	315-0103-00		10 k Ω	1/4 W		5%
R181	316-0154-00		150 k Ω	1/4 W		
R182	316-0105-00		1 M Ω	1/4 W		
R184	315-0103-00		10 k Ω	1/4 W		5%
R185	316-0124-00		120 k Ω	1/4 W		
R187	316-0105-00		1 M Ω	1/4 W		
R200	315-0270-00	B010100 B039999X	27 Ω	1/4 W		5%
R203	322-0624-07		990 k Ω	1/4 W	Prec	1/10%
R206	322-0481-07		1 M Ω	1/4 W	Prec	1/10%
R208	321-0289-03		10 k Ω	1/8 W	Prec	1/4%
R211	321-0261-00		5.11 k Ω	1/8 W	Prec	1%
R220	315-0201-00		200 Ω	1/4 W		5%
R227	311-0622-00		100 Ω , Var			
R240	321-0933-03		6.66 k Ω	1/8 W	Prec	1/4%
R241	321-0932-03		2.5 k Ω	1/8 W	Prec	1/4%
R242	321-0931-03		1.11 k Ω	1/8 W	Prec	1/4%
R243	321-0660-03		417 Ω	1/8 W	Prec	1/4%
R244	321-0930-03		204 Ω	1/8 W	Prec	1/4%
R245	321-1097-03		101 Ω	1/8 W	Prec	1/4%
R246	321-0030-03		20 Ω	1/8 W	Prec	1/4%
R249	321-0030-03		20 Ω	1/8 W	Prec	1/4%
R251	321-0222-00		2 k Ω	1/8 W	Prec	1%
R253	321-0231-00		2.49 k Ω	1/8 W	Prec	1%

with a zero input signal to set the voltage across the Variable control (R169) in the output amplifier stage to zero volts. With both sides of the amplifier so balanced, trace deflection is prevented as the Variable control is rotated throughout its range.

Normally, the frequency response of the preamplifier is from DC to at least one megahertz; however, for low-frequency applications where high input sensitivities are used, the overall frequency response can be limited to about ten kilohertz to reduce noise referred to the input. This is achieved by pushing the BANDWIDTH LIMIT 10 kHz switch, S259, which connects C259 across the output of the preamplifier stage. Different frequency limitations can be chosen by changing the value of C259. Frequency cut off point will vary inversely proportional to the capacitance chosen and noise factor will increase with increasing frequency.

Common-Mode Rejection

One of the primary functions of the preamplifier is to reject any common-mode component of the input signal and amplify only the difference. Assume that the inputs are tied together and a voltage is applied to the common input. The amplifier differential output is ideally zero, and would actually be zero provided that the characteristics of all corresponding elements on the two sides of the amplifier were matched (e.g., Q120A and Q120B transconductance and μ , Q129A and Q129B beta, current sources, etc.). In practice, any mismatch will cause a differential output.

Floating Power Supply. A floating power supply made up of Q130, Q140, Q146 and Zener diodes VR148 and VR149 minimize inherent common-mode difficulties and therefore improves the common-mode rejection ratio (refer to Fig. 3-2). Q146 is a constant-current high-impedance source for Q140, and Q130 is the current return for the preamplifier stage.

The input to the bootstrap (X1 gain) amplifier is connected to the junction of R140 and R141. The bootstrap amplifier portion of the supply consists of emitter-follower Q140 and DC level-shifting Zener diodes VR148 and VR149. The collector impedance of Q146 presents minimum loading to the Q140 output and maintains the gain of the amplifier (bootstrap efficiency) very close to one.

The entire power supply and amplifier voltages move an amount equal to the common-mode voltage, maintaining a constant operating characteristic of the elements in the preamplifier stage. Since no signal current is developed, the output at the collectors of Q150A and Q150B remains unchanged; that is, the common-mode signal is rejected.

C221 (CMRR 1) and C250 (CMRR 2) are adjusted on high-frequency common-mode signals to normalize the effective capacitance of the active devices on one side of the amplifier to the other.

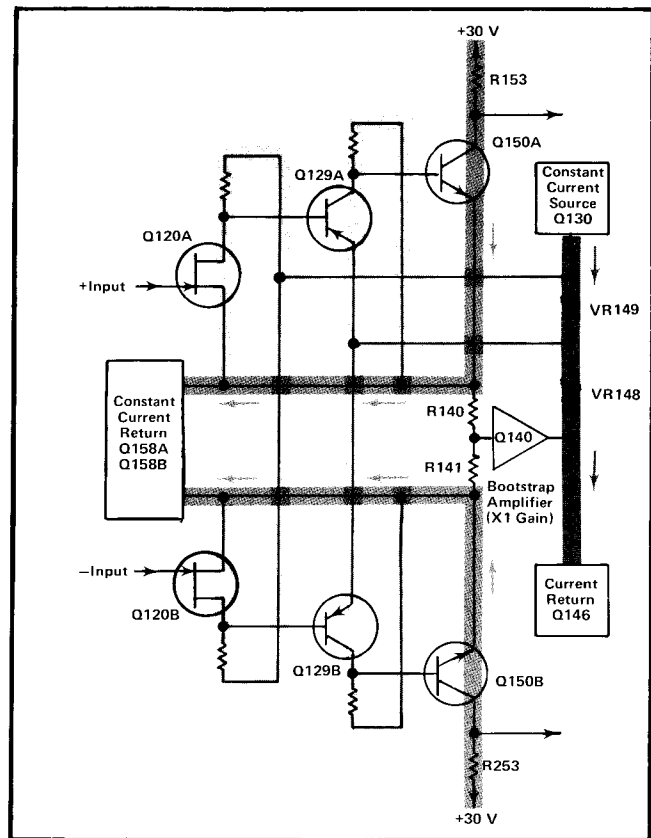

Fig. 3-2. Floating Power Supply detailed block diagram showing standing current paths through the Preamp.

Isolation Stage

The differential signal developed at the collectors of Q150A and Q150B is passed through emitter followers Q160 and Q260 to the output amplifier. Q160 and Q260 isolate the preamplifier from the loading of the output amplifier and trigger signal amplifier.

Output Amplifier

The output amplifier consists of push-pull amplifier Q163-Q263. With a signal applied, potentiometer R268, Gain, provides emitter degeneration. The gain is determined by the total emitter resistance. This allows the overall gain of the 5A20N to be adjusted to match the mainframe requirements. Also, the Variable Volts/Div control, R169, allows gain to be adjustable over a 2.5 to 1 ratio.

Q170 and Q270 are positioning-current drivers. R179, POSITION, provides an adjustable change in the conduction of the transistors, which provide a current to either add to or subtract from the Q163-Q263 currents to alter the quiescent vertical position of the display.

MAIN Circuit Board Assembly (cont)

Ckt. No.	Tektronix Part No.	Serial/Model No. Eff	Disc	Description		
Transistors (cont)						
Q263	* 151-0219-00		Silicon	PNP	TO-18	Replaceable by 2N4250
Q270	151-0341-00		Silicon	NPN	TO-106	2N3565
Q280	* 151-0219-00		Silicon	PNP	TO-18	Replaceable by 2N4250
Q281	151-0341-00		Silicon	NPN	TO-106	2N3565
Q286	* 151-0219-00		Silicon	PNP	TO-18	Replaceable by 2N4250

Resistors

Resistors are fixed, composition, $\pm 10\%$ unless otherwise indicated.

R4	316-0105-00		1 M Ω	1/4 W		
R14	316-0105-00		1 M Ω	1/4 W		
R22	316-0100-00		10 Ω	1/4 W		
R100	315-0270-00	B010100	B039999X 27 Ω	1/4 W		5%
R103	322-0624-07		990 k Ω	1/4 W	Prec	1/10%
R106	322-0481-07		1 M Ω	1/4 W	Prec	1/10%
R108	321-0289-03		10 k Ω	1/8 W	Prec	1/4%
R109	311-0605-00		200 Ω , Var			
R111	315-0153-00		15 k Ω	1/4 W		5%
R114	315-0242-00		2.4 k Ω	1/4 W		5%
R120	315-0201-00		200 Ω	1/4 W		5%
R121	321-0261-00		5.11 k Ω	1/8 W	Prec	1%
R125	321-0078-00		63.4 Ω	1/8 W	Prec	1%
R126	321-0126-00		200 Ω	1/8 W	Prec	1%
R127	311-1116-00		100 Ω , Var			
R131	315-0270-00		27 Ω	1/4 W		5%
R135	315-0331-00		330 Ω	1/4 W		5%
R137	315-0362-00		3.6 k Ω	1/4 W		5%
R140	321-0816-03		5 k Ω	1/8 W	Prec	1/4%
R141	321-0816-03		5 k Ω	1/8 W	Prec	1/4%
R144	315-0153-00		15 k Ω	1/4 W		5%
R145	315-0153-00		15 k Ω	1/4 W		5%
R146	315-0682-00		6.8 k Ω	1/4 W		5%
R151	321-0222-00		2 k Ω	1/8 W	Prec	1%
R152	321-0216-00		1.74 k Ω	1/8 W	Prec	1%

Circuit Description—5A20N

Trigger Signal Amplifier

Differential amplifier Q280-Q286 receives the triggering signal from the emitters of Q160 and Q260 in the isolation stage. The triggering signal is amplified and passed through emitter-follower Q288, where it is made available to an associated time-base unit via output terminal A4. The triggering signal is of the same polarity as that applied to the gate of Q120A, and has an amplitude of about 0.25 volt per displayed division.

Vertical Switching and Readout

The VOLTS/DIV switch, S240, is made up of a series of cam lobes, which engage and disengage various contacts at different positions of the switch. Cams 1 through 4 control switching of the input attenuators and cams 5 through 13 control switching of the gain-setting resistor R240-R249 in the preamplifier stage. Those contacts that are engaged at

any given position of the switch are shown by black dots on the switch logic diagram.

Either of two lamp bulbs located behind the knob skirt of the VOLTS/DIV switch illuminates the selected deflection factor to provide a direct readout. Normally, DS182, which is physically located behind the upper left portion of the knob skirt, is lit. Connection of a readout-coded 10X probe to either the + or – input automatically changes the readout by a factor of 10 (i.e., extinguishes DS182 and illuminates DS187) to reflect the correction of probe attenuation, eliminating possible error by the operator of the instrument. J1 and J11, the + and – input connectors, have probe rings, allowing the 10X probe to apply a ground connection to the base of Q182. Q182 turns off, allowing Q187 to turn on, switching current from DS182 to DS187. When the instrument is operated in the CURR PROBE ONLY mode, DS187 is illuminated to indicate the vertical deflection factor in units of amperes per division.

MAIN Circuit Board Assembly (cont)

Ckt. No.	Tektronix Part No.	Serial/Model No. Eff	No. Disc	Description		
Semiconductor Device, Diodes						
CR111	*152-0324-00		Silicon			Tek Spec
CR112	*152-0324-00		Silicon			Tek Spec
CR113	*152-0324-00		Silicon			Tek Spec
CR114	*152-0324-00		Silicon			Tek Spec
CR163	*152-0185-00		Silicon			Replaceable by 1N4152
CR263	*152-0185-00		Silicon			Replaceable by 1N4152
VR111	152-0168-00		Zener	1N963A		400 mW, 12 V, 5%
VR114	152-0168-00		Zener	1N963A		400 mW, 12 V, 5%
VR148	152-0280-00		Zener	1N753A		400 mW, 6.2 V, 5%
VR149	152-0279-00		Zener	1N751A		400 mW, 5.1 V, 5%
Fuses						
F20	159-0024-00	<i>select for</i>	1/16 A		3AG	Fast-Blo
F206	159-0024-00	<i>low noise</i>	1/16 A		3AG	Fast-Blo
Inductors						
L174	*108-0200-00		40 μ H			
L274	*108-0200-00		40 μ H			
LR100	*108-0565-00	XB040000	5 μ H			(wound on a 200 Ω , 1/4 W, 5% resistor)
LR120	*108-0565-00	XB050000	5 μ H			(wound on a 200 Ω , 1/4 W, 5% resistor)
LR200	*108-0565-00	XB040000	5 μ H			(wound on a 200 Ω , 1/4 W, 5% resistor)
LR220	*108-0565-00	XB050000	5 μ H			(wound on a 200 Ω , 1/4 W, 5% resistor)
Transistors						
Q120A,B	*151-1049-00		Silicon	JFET	TO-71	Tek Spec
Q129A,B	*151-0261-00		Silicon	PNP	TO-78	Tek Spec, dual
Q130	151-0220-00		Silicon	PNP	TO-18	2N4122
Q140	151-0273-00		Silicon	NPN	TO-98	2N5249
Q146	151-0341-00		Silicon	NPN	TO-106	2N3565
Q150A,B	*151-0232-00		Silicon	NPN	TO-78	Tek Spec, dual
Q158A,B	*151-0232-00		Silicon	NPN	TO-78	Tek Spec, dual
Q160	151-0341-00		Silicon	NPN	TO-106	2N3565
Q163	*151-0219-00		Silicon	PNP	TO-18	Replaceable by 2N4250
Q170	151-0341-00		Silicon	NPN	TO-106	2N3565
Q182	151-0347-00		Silicon	NPN	TO-92	2N5551
Q187	151-0347-00		Silicon	NPN	TO-92	2N5551
Q260	151-0341-00		Silicon	NPN	TO-106	2N3565

SECTION 4

CALIBRATION

Change information, if any, affecting this section will be found at the rear of this manual.

Introduction

Before complete calibration, thoroughly clean and inspect this instrument as outlined in the Maintenance section of the Oscilloscope System manual.

Services Available

Tektronix, Inc. provides complete instrument repair and recalibration at the local Field Service Centers and the Factory Service Center. Contact your local Tektronix Field Office or representative for further information.

Using This Procedure

General. This section provides several features to facilitate checking or adjusting the 5A20N. These are:

Index. To aid in locating a step in the Performance Check or Adjustment procedure, an index is given preceding Part I – Performance Check and Part II – Adjustment procedure.

Performance Check. The performance of this instrument can be checked without removing the covers or making internal adjustments by performing only Part I – Performance Check. This procedure checks the instrument against the tolerances listed in the Performance Requirement column of Section 1. Also, a reference is made to the step in Part II – Adjustment which will return the instrument to the correct calibration. In most cases, the adjustment step can be performed without changing control settings or equipment connections.

Adjustment Procedure. To return this instrument to correct calibration with the minimum number of steps, perform only Part II – Adjustment. The Adjustment procedure gives the recommended calibration procedure for all circuits in this instrument. Procedures are not given for checks which can be made without removing the covers; see Part I – Performance Check for the correct procedure for making these checks.

Complete Performance Check/Adjustment. To completely check and adjust all parts of this instrument, perform both Parts I and II. Start the complete procedure by

removing instrument covers as outlined in the Preliminary Procedure of Part II – Adjustment. Then follow the Performance Check, referring to the Adjustment procedure as directed to make the actual adjustments. This method will ensure that the instrument is both correctly adjusted and performing within all given specifications.

TEST EQUIPMENT REQUIRED

General

The following test equipment and accessories, or its equivalent, is required for complete calibration of the 5A20N. Specifications given for the test equipment are the minimum necessary for accurate calibration. Therefore, some of the specifications listed here may be somewhat less rigorous than the actual performance capabilities of the test equipment. All test equipment is assumed to be correctly calibrated and operating within the listed specifications.

The Performance Check and Adjustment procedures are based on this recommended equipment. If other equipment is substituted, control settings or calibration setup may need to be altered to meet the requirements of the equipment used. Detailed operating instructions for the test equipment are not given in this procedure. Refer to the instruction manual for the test equipment if more information is needed.

Special Calibration Fixtures

Special Tektronix calibration fixtures are used in this procedure only where they facilitate instrument calibration. These special calibration fixtures are available from Tektronix, Inc. Order by part number through your local Tektronix Field Office or representative.

Calibration Equipment Alternatives

All of the test equipment is required to completely check and adjust this instrument. However, some of the items used only for the Performance Check can be deleted without compromising the measurement capabilities of the instrument.

MAIN Circuit Board Assembly (cont)

Kct. No.	Tektronix Part No.	Serial/Model No. Eff	Disc	Description		
Capacitors (cont)						
C13	281-0081-00		1.8-13 pF, Var	Air		
C101	281-0658-00		6.2 pF	Cer	500 V	±0.25 pF
C104	281-0628-00	B0101000 B029999	15 pF	Cer	600 V	5%
C104	281-0657-00	B030000	13 pF	Cer	500 V	2%
C108	283-0626-00		1800 pF	Mica	500 V	5%
C111	290-0267-00		1 μF	Elect.	35 V	
C121	281-0604-00		2.2 pF	Cer	500 V	±0.25 pF
C122	281-0604-00		2.2 pF	Cer	500 V	±0.25 pF
C129	281-0709-00		7 pF	Cer	500 V	±0.1 pF
C131	281-0504-00		10 pF	Cer	500 V	10%
C135	290-0267-00		1 μF	Elect.	35 V	
C140	281-0534-00	B010100 B039999	3.3 pF	Cer	500 V	±0.25 pF
C140	281-0504-00	B040000	10 pF	Cer	500 V	10%
C148	290-0297-00		39 μF	Elect.	10 V	10%
C149	290-0297-00		39 μF	Elect.	10 V	10%
C150	281-0618-00		4.7 pF	Cer	200 V	±0.5 pF
C158	281-0504-00		10 pF	Cer	500 V	10%
C163	281-0540-00		51 pF	Cer	500 V	5%
C170	283-0000-00		0.001 μF	Cer	500 V	
C181	283-0002-00		0.01 μF	Cer	500 V	
C184	283-0002-00		0.01 μF	Cer	500 V	
C204	281-0628-00	B010100 B029999	15 pF	Cer	500 V	5%
C204	281-0657-00	B030000	13 pF	Cer	500 V	2%
C208	283-0626-00		1800 pF	Mica	500 V	5%
C221	281-0114-00		1.3-5.4 pF, Var	Air		
C229	281-0709-00		7 pF	Cer	500 V	±0.1 pF
C250	281-0077-00		1.3-5.4 pF, Var	Air		
C256	283-0003-00		0.01 μF	Cer	150 V	
C259	283-0041-00		0.0033 μF	Cer	500 V	5%
C263	281-0540-00		51 pF	Cer	500 V	5%
C279	281-0586-00		25 pF	Cer	500 V	5%
C281	281-0534-00		3.3 pF	Cer	500 V	±0.25 pF
C287	290-0134-00		22 μF	Elect.	15 V	

Calibration—5A20N

Test Equipment

1. 5100N-series oscilloscope. For this procedure, a 5103N/D10 with a 5B10N time-base is used.

2. Standard amplitude calibrator. Output signal, one-kilohertz square-wave; output amplitude, .2 millivolt to 100 volts; amplitude accuracy, within 0.25%; must have a 5-milliampere current loop. Tektronix calibration fixture 067-0502-01 recommended.

3. Constant-amplitude sine-wave generator. Frequency, 2 hertz to 2 megahertz; output amplitude, from about 0.5 volt to 40 volts peak to peak. For example, General Radio 1310-A Oscillator (use a General Radio Type 274 QBJ Adapter to provide BNC output).

Accessories

4. Plug-in extension for the 5100N-series oscilloscope (for adjustment procedure only).

5. Coaxial cable. Impedance, 50 ohms; length, 42 inches; connectors, BNC. Tektronix Part No. 012-0057-01.

6. Dual-input cable. Provides matches signal paths to the + and - inputs; BNC connectors. Tektronix Calibration Fixture 067-0525-00 recommended.

7. Input RC Normalizer. RC time constant 47 μs (1 MΩ X 47 pF); connectors, BNC. Tektronix Calibration Fixture 067-0541-00.

8. In-line termination. Impedance, 50 ohms, accuracy, ±2%, connectors, BNC. Tektronix Part No. 011-0049-01.

9. 1000:1 divider. Tektronix Calibration Fixture 067-0529-00.

10. 10X attenuator (2 needed). Impedance, 50 ohms; accuracy, ±2%; connectors, BNC. Tektronix Part No. 011-0059-02.

11. Variable attenuator. A variable attenuator that has the end terminals of a 100-ohm potentiometer connected from input to ground, and the potentiometer divider arm connects to the attenuator output. Tektronix Calibration Fixture 067-0511-00 recommended.

12. Adapter, GR to BNC female. Tektronix Part No. 017-0063-00.

13. Adapter, GR to BNC male. Tektronix Part No. 017-0064-00.

Preliminary Control Settings

Set the 5A20N and Oscilloscope System controls as follows (for both Performance Check and Adjustment procedure):

5A20N

DISPLAY	ON (readout illuminates when power is on)
POSITION	Midrange
BANDWIDTH LIMIT	1 MHz (button out)
VOLTS/DIV	50 m
Variable Volts/Div	CAL detent (fully clockwise)
STEP ATTEN BAL	Midrange
+ Input Coupling	DC, GND
- Input Coupling	DC, GND

Oscilloscope

Mainframe (5103N/DM10)	
Intensity	Normal display brightness
Focus	Adjust for best focus of trace
Time Base (5B10N)	
Display	Alt (button out)
Position	Sweep starts at left edge of graticule
Seconds/Div	1 m
Variable Seconds/Div	Cal detent
Swp Mag	Off (button out)
Triggering Mode	Auto Trig, AC Coupling, + Slope
Triggering Source	Left
Triggering Level	Midrange

SECTION 5

ELECTRICAL PARTS LIST

Values are fixed unless marked Variable.

Ckt. No.	Tektronix Part No.	Serial/Model No. Eff	Disc	Description
----------	-----------------------	-------------------------	------	-------------

CHASSIS

Capacitors

Tolerance $\pm 20\%$ unless otherwise indicated.

C4 C14	*295-0142-00		0.1 μ F	(matched pair)
-----------	--------------	--	-------------	----------------

Bulbs

DS182	150-0111-00		Neon, AIC	
DS187	150-0111-00		Neon, AIC	

Connectors

J1	131-0679-00	B010100	B044726	BNC, receptacle, electrical
J1	131-0679-02	B044727		BNC, receptacle, electrical
J11	131-0679-00	B010100	B044726	BNC, receptacle, electrical
J11	131-0679-02	B044727		BNC, receptacle, electrical

Resistor

Resistors are fixed, composition, $\pm 10\%$ unless otherwise indicated.

R179	311-0310-01	B010100	B039999	5 k Ω , Var
R179	311-1368-00	B040000		5 k Ω , Var

MAIN Circuit Board Assembly

*670-1368-00	B010100	B039999	Complete Board
*670-1368-01	B040000		Complete Board

Capacitors

Tolerance $\pm 20\%$ unless otherwise indicated.

C1	281-0081-00		1.8-13 pF, Var	Air
C2	281-0078-00		1.4-7.3 pF, Var	Air
C3	281-0081-00		1.8-13 pF, Var	Air
C11	281-0081-00		1.8-13 pF, Var	Air
C12	281-0078-00		1.4-7.3 pF, Var	Air

PART I—PERFORMANCE CHECK

Introduction

The following procedure checks the performance of the 5A20N without removing the covers or making internal adjustments. All tolerances given in this procedure are based on Section 1.

Index to Part I — Performance Check

	Page
1. Check Variable Balance	4-3
2. Check DC Balance	4-3
3. Check Amplifier Gain and VOLTS/DIV Switch Accuracy	4-3
4. Check Input Compensation	4-4
5. Check Attenuator Low Frequency CMRR	4-4
6. Check High Frequency CMRR	4-5
7. Check Amplifier Bandwidth	4-5
8. Check Input Gate Current	4-5
9. Check Amplifier Noise Level	4-6

Preliminary Procedure for Performance Check

NOTE

The performance of this instrument can be checked at any temperature within the 0°C to +50°C range unless stated otherwise.

1. Insert the 5A20N into the left plug-in compartment of the 5103N Oscilloscope System mainframe. Insert a 5B10N time-base unit into the right compartment.

2. Connect the oscilloscope to the power source for which it is wired and turn on the power.

3. Set the controls as given under Preliminary Control Settings.

1. Check Variable Balance

a. Move the trace to the graticule center horizontal line with the POSITION control.

b. Rotate the Variable Volts/Div control counterclockwise.

c. CHECK—Trace should not shift more than one division as the Variable control is rotated throughout its range.

d. CALIBRATION—If shift is excessive, perform step 1 of the Adjustment procedure.

e. Return the Variable control to the CAL detent position.

2. Check DC Balance

a. Turn the VOLTS/DIV switch throughout its range.

b. CHECK—Trace should not shift more than one division. Adjust the front-panel STEP ATTEN BAL control for minimum trace shift as the VOLTS/DIV switch is rotated throughout its range. Readjust the POSITION control, if necessary, to return the trace to graticule center after minimum shift has been attained.

c. CALIBRATION—If balance cannot be achieved, center the STEP ATTEN BAL control and perform step 2 of the Adjustment procedure.

3. Check Amplifier Gain and VOLTS/DIV Switch Accuracy

AMPLIFIER GAIN

a. Connect the standard amplitude calibrator output connector to the + input connector through a coaxial cable. Set the standard amplitude calibrator for a 5-millivolt square-wave output.

b. Set the VOLTS/DIV switch to 1 mV and release the + Input Coupling GND (button out).

c. CHECK—Display amplitude is five divisions, ± 0.1 division. Adjust positioning as required.

d. CALIBRATION—If amplitude is out of the specified tolerance, perform step 3 of the Adjustment procedure.

PARTS ORDERING INFORMATION

Replacement parts are available from or through your local Tektronix, Inc. Field Office or representative.

Changes to Tektronix instruments are sometimes made to accommodate improved components as they become available, and to give you the benefit of the latest circuit improvements developed in our engineering department. It is therefore important, when ordering parts, to include the following information in your order: Part number, instrument type or number, serial or model number, and modification number if applicable.

If a part you have ordered has been replaced with a new or improved part, your local Tektronix, Inc. Field Office or representative will contact you concerning any change in part number.

SPECIAL NOTES AND SYMBOLS

- | | |
|-----------------|---|
| ×000 | Part first added at this serial number |
| 00× | Part removed after this serial number |
| *000-0000-00 | Asterisk preceding Tektronix Part Number indicates manufactured by or for Tektronix, Inc., or reworked or checked components. |
| Use 000-0000-00 | Part number indicated is direct replacement. |

Performance Check—5A20N

VOLTS/DIV ACCURACY

e. CHECK—Using the VOLTS/DIV switch and standard amplitude calibrator switch settings given in Table 4-1, check the VOLTS/DIV switch accuracy. Set the BANDWIDTH LIMIT switch to 10 kHz for the more sensitive positions.

TABLE 4-1

VOLTS/DIV Switch Setting	Standard Amplitude Calibrator Output	CRT Display (Vertical Deflection)
5 V	20 volts	4 div, ± 0.08 div
2 V	10 volts	5 div, ± 0.1 div
1 V	5 volts	5 div, ± 0.1 div
.5 V	2 volts	4 div, ± 0.08 div
.2 V	1 volt	5 div, ± 0.1 div
.1 V	.5 volt	5 div, ± 0.1 div
50 mV	.2 volt	4 div, ± 0.08 div
20 mV	.1 volt	5 div, ± 0.1 div
10 mV	50 mV	5 div, ± 0.1 div

Connect a 1000:1 divider between the calibrator output and the + input connector to check higher sensitivity ranges.

5 mV	20 V	4 div, ± 0.08 div
2 mV	10 V	5 div, ± 0.1 div
1 mV	5 V	5 div, ± 0.1 div
.5 mV	2 V	4 div, ± 0.08 div
.2 mV	1 V	5 div, ± 0.1 div
.1 mV	.5 V	5 div, ± 0.1 div
50 μ V	.2 V	4 div, ± 0.08 div

f. Remove the 1000:1 divider.

4. Check Input Compensation

a. Insert a 47 pF input RC normalizer between the signal cable and the + input connector. Set the VOLTS/DIV switch to .1 V and the BANDWIDTH LIMIT to 1 MHz (button out).

b. Set the standard amplitude calibrator for a 1-volt square wave output (five divisions displayed).

c. CHECK—Optimum square leading corner of the square-wave display. Aberrations are not to exceed + or – 2%, or 3% overall on any of the checks. If roll-off or overshoot is objectionable, perform step 4 of the Adjustment procedure.

d. Set the standard amplitude calibrator for a .5-volt square-wave output and change the VOLTS/DIV switch to 50 mV.

e. CHECK—Optimum square leading corner of the square-wave display. If roll-off or overshoot is objectionable, perform step 4 of the Adjustment procedure.

f. Move the RC normalizer and calibrator signal from the + input to the – input.

g. Set the + Input Coupling to GND and the – Input Coupling to DC. Position the display to the center of the graticule area.

h. Set the VOLTS/DIV switch to .1 V and set the standard amplitude calibrator for a 1-volt square-wave output.

i. CHECK—Optimum square leading corner of the square-wave display. If roll-off or overshoot is objectionable, perform step 4 of the Adjustment procedure.

j. Set the standard amplitude calibrator for a .5-volt square-wave output and change the VOLTS/DIV switch to 50 mV.

k. CHECK—Optimum square leading corner of the square-wave display. If roll-off or overshoot is objectionable, perform step 4 of the Adjustment procedure.

l. Disconnect the RC normalizer and standard amplitude calibrator.

5. Check Attenuator Low-Frequency CMRR

a. Set the controls as follows:

VOLTS/DIV	5 V
+ and – Input Coupling	GND
Seconds/Div (time-base)	5 ms

b. Connect a dual input cable to the + and – input connectors. Connect a sine-wave generator output to the dual-input cable through a coaxial cable.

c. Set the sine-wave generator for a 100-hertz, 40-volt peak to peak reference signal (set the + Input Coupling to DC and obtain exactly eight divisions of vertical deflection).

d. Set the – Input Coupling to DC (both the + and – Input Coupling switches should be set to DC) and the VOLTS/DIV switch to .2 V.

PARTS LIST ABBREVIATIONS

BHB	binding head brass	int	internal
BHS	binding head steel	lg	length or long
cap.	capacitor	met.	metal
cer	ceramic	mtg hdw	mounting hardware
comp	composition	OD	outside diameter
conn	connector	OHB	oval head brass
CRT	cathode-ray tube	OHS	oval head steel
csk	countersunk	P/O	part of
DE	double end	PHB	pan head brass
dia	diameter	PHS	pan head steel
div	division	plstc	plastic
elect.	electrolytic	PMC	paper, metal cased
EMC	electrolytic, metal cased	poly	polystyrene
EMT	electrolytic, metal tubular	prec	precision
ext	external	PT	paper, tubular
F & I	focus and intensity	PTM	paper or plastic, tubular, molded
FHB	flat head brass	RHB	round head brass
FHS	flat head steel	RHS	round head steel
Fil HB	fillister head brass	SE	single end
Fil HS	fillister head steel	SN or S/N	serial number
h	height or high	S or SW	switch
hex.	hexagonal	TC	temperature compensated
HHB	hex head brass	THB	truss head brass
HHS	hex head steel	thk	thick
HSB	hex socket brass	THS	truss head steel
HSS	hex socket steel	tub.	tubular
ID	inside diameter	var	variable
inc	incandescent	w	wide or width
		WW	wire-wound

e. CHECK—Vertical deflection is 0.2 division or less. Displayed signal of 40 millivolts (0.2 division), or less, of a 40-volt signal, indicates that CMRR is at least 1000:1 (60 dB). If vertical deflection is greater than 0.2 division, perform step 5 of the Adjustment procedure.

f. Change the sine-wave generator frequency to one kilohertz.

g. CHECK—Vertical deflection is 0.2 division or less.

6. Check High Frequency CMRR

a. Set the sine-wave generator for a 20-volt, 30-kilohertz output (set the VOLTS/DIV switch to 5 V, — Input Coupling to GND and obtain exactly four vertical divisions of display).

b. Set the — Input Coupling to DC and the VOLTS/DIV switch to 50 mV.

c. CHECK—Vertical deflection for all VOLTS/DIV switch ranges from 50 mV to .1 mV is two divisions or less; for 50 μ V, four divisions or less.

d. CALIBRATION—If more than two divisions of vertical display are present at these ranges, perform step 6 of the Adjustment procedure.

7. Check Amplifier Bandwidth

a. Set the sine-wave generator for minimum output amplitude.

b. Change the controls as follows:

VOLTS/DIV	.1 V
+ Input Coupling	AC
— Input Coupling	GND
Seconds/Div (time base)	.5 ms

c. Adjust the sine-wave generator for eight vertical divisions of one-kilohertz display as a reference. Then slowly increase the frequency until the display amplitude is 5.66 divisions. This is the upper -3 dB point.

d. CHECK—Frequency at the upper -3 dB point must be at least one megahertz.

e. Set the BANDWIDTH LIMIT to 10 kHz (button in) and adjust the sine-wave generator for eight vertical divi-

sions of 2-kilohertz reference display. Then slowly increase the frequency until the display amplitude is 5.66 divisions.

f. CHECK—Frequency at the upper -3 dB point (bandwidth limited) is between 8 kHz and 12 kHz.

g. Release the BANDWIDTH LIMIT switch (button out) and adjust the sine-wave generator for eight vertical divisions of 2-kilohertz reference display. Then slowly decrease the frequency until the display amplitude is 5.66 divisions. This is the lower -3 dB point when AC coupling is used (determined by the coupling capacitor). Set the time-base Seconds/Div as necessary to view the signal.

h. CHECK—Frequency at the lower -3 dB point is two hertz or less.

i. Disconnect the sine-wave generator.

8. Check Input Gate Current

a. Position the trace to the graticule center, then change the following control settings:

VOLTS/DIV	50 μ V
+ Input Coupling	AC, GND
— Input Coupling	AC, GND
Seconds/Div (time base)	1 ms

b. Connect a 50-ohm termination to the + input connector and using the STEP ATTEN BAL control, position the trace to the graticule centerline.

c. Release the GND button of the + Input Coupling switch (input AC-coupled).

d. CHECK—Trace shift is less than ± 2 divisions. This indicates an FET gate current of 100 picoamperes or less.

e. Ground the + Input Coupling (GND button in) and move the 50-ohm termination to the — input connector.

f. Release the GND button of the — Input Coupling switch.

g. CHECK—Trace shift is less than ± 2 divisions.

h. Remove the 50-ohm termination.

PART II—ADJUSTMENT

Introduction

The following procedure returns the 5A20N to correct calibration. All limits and tolerances given in this procedure are calibration guides and should not be interpreted as instrument specifications except as given in Section 1 of this manual. The actual performance of the instrument may exceed the given limits or tolerances if the instrument meets the Performance Requirements as checked in Part I — Performance Check of this section. Location of internal adjustments is shown in Fig. 4-1.

Index to Part II — Adjustment

	Page
1. Adjust Variable Balance (R159)	4-8
2. Adjust DC Balance (R227)	4-8
3. Adjust Amplifier Gain (R268)	4-8
4. Adjust Input Compensation (C1, C2, C3, C11, C12, C13)	4-8

5. Adjust Attenuator Low Frequency CMRR (R109) 4-9

6. Adjust High Frequency CMRR (C221 and C250) 4-9

Preliminary Procedure For Adjustment

NOTE

This instrument should be adjusted at an ambient temperature of $25^{\circ}\text{C} \pm 5^{\circ}\text{C}$ for best overall accuracy.

1. Remove the dust cover from the left side of the 5A20N and remove the cabinet panel from the left side of the 5103N Oscilloscope System mainframe.

2. Place the 5A20N on a plug-in extender and insert the extender into the left plug-in compartment of the 5103N Oscilloscope System mainframe. Insert a 5B10N time-base unit into the right compartment.

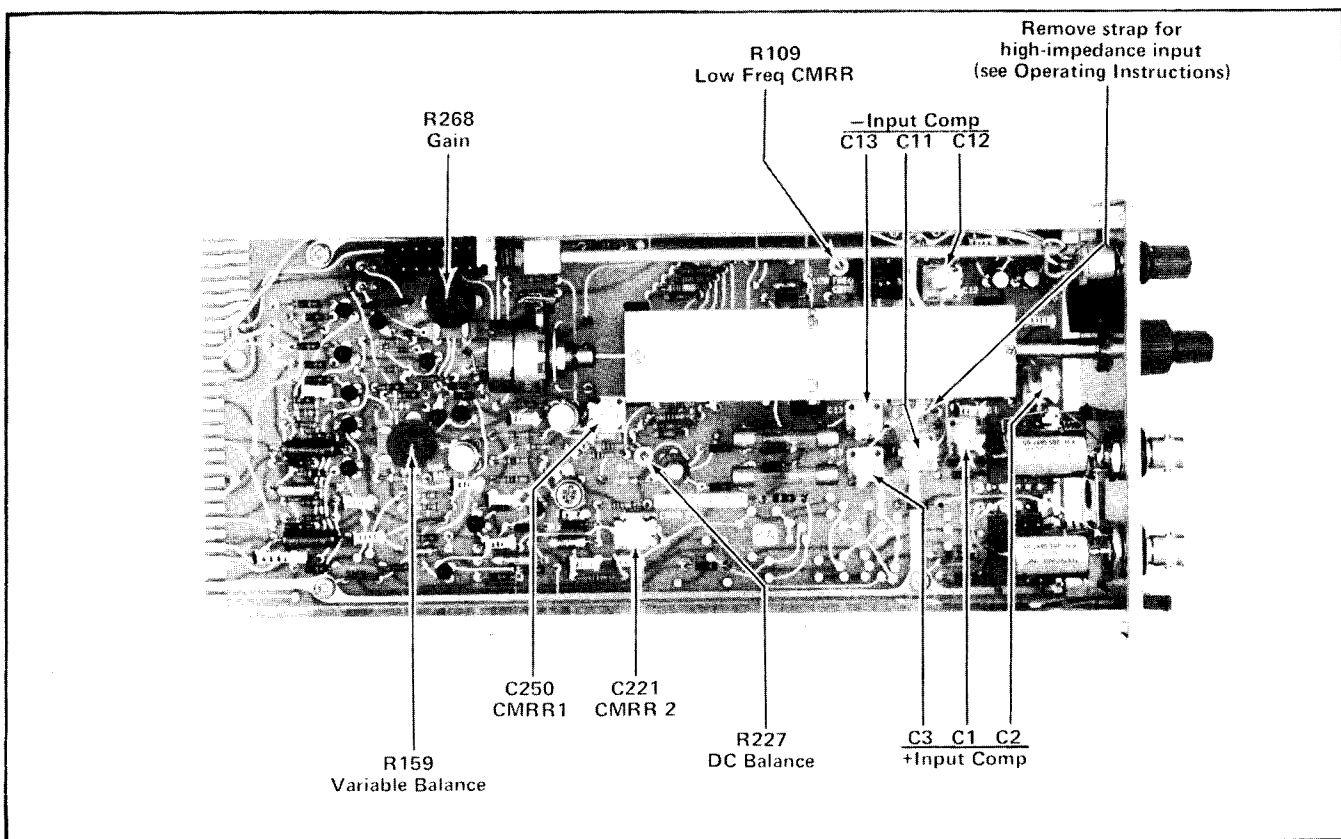

Fig. 4-1. Location of internal controls in the 5A20N.

Adjustment—5A20N

3. Connect the oscilloscope to the power source for which it is wired and turn on the power.

4. Set the controls as given under Preliminary Control Settings.

1. Adjust Variable Balance (R159)

a. Move the trace to the graticule center horizontal line with the POSITION control.

b. Rotate the Variable Volts/Div control counterclockwise.

c. ADJUST—R159, Var Bal, for minimum trace shift as the Variable Volts/Div control is rotated throughout its range. Re-adjustment of the POSITION control may be necessary to return the trace to graticule center after the minimum shift has been attained.

d. Return the Variable control to the CAL detent position.

2. Adjust DC Balance (R227)

a. With the STEP ATTEN BAL control centered, turn the VOLTS/DIV switch throughout its range.

b. ADJUST—If the trace goes off-screen, start at the position of the VOLTS/DIV switch at which an on-screen display is obtained and adjust R227, Coarse DC Bal, working down to the 50 μ V position so the trace remains on-screen at 50 μ V. Make the fine adjustment to bring the trace to screen center with the front-panel STEP ATTEN BAL control. Maximum allowable shift of trace is one division as the VOLTS/DIV switch is rotated.

3. Adjust Amplifier Gain (R268)

a. Connect the standard amplitude calibrator output connector to the + input connector through a coaxial cable. Set the standard amplitude calibrator for a 5-millivolt square-wave output.

b. Set the VOLTS/DIV switch to 1 mV and release the + Input Coupling GND (button out).

c. ADJUST—R268, Gain, for a display amplitude of exactly five divisions.

4. Adjust Input Compensation (C1, C2, C3, C11, C12, C13)

a. Set the VOLTS/DIV switch to .1 V.

b. Insert a 47 pF input RC normalizer between the signal cable and the + input connector.

c. Set the standard amplitude calibrator for a 1-volt square-wave output (five divisions displayed).

d. ADJUST—C1 and C2 for minimum roll-off or overshoot of leading corner of square-wave display.

e. Set the standard amplitude calibrator for a .5-volt square-wave output, and change the VOLTS/DIV switch to 50 mV.

f. ADJUST—C3 for minimum roll-off or overshoot of leading corner of square-wave display.

g. Move the RC normalizer and calibrator signal from the + input to the – input.

h. Set the + Input Coupling to GND and the – Input Coupling to DC. Position the display to the center of the graticule area.

i. Set the VOLTS/DIV switch to .1 V and set the standard amplitude calibrator for a 1-volt square-wave output.

j. ADJUST—C11 and C12 for minimum roll-off or overshoot of leading corner of square-wave display.

k. Set the standard amplitude calibrator for a .5-volt square-wave output and change the VOLTS/DIV switch to 50 mV.

l. ADJUST—C13 for minimum roll-off or overshoot of leading corner of square-wave display.

m. Disconnect the RC normalizer and standard amplitude calibrator.